

# NEEDLE ROLLER BEARINGS



# 1 Bearing Life and Load Rating

## 1-1 Bearing life

Bearings are subjected to certain intensity of repeating stress on their track ring and rolling element even during operation under proper loading, appropriate mounting and sufficient lubrication. The stress may cause scaly damage formed on surface after certain time period due to its concentration at shallow vicinity under the surface. This phenomenon is called flaking (peeling-off of surface). Phenomenon that causes bearing to be unusable due to flaking caused by repeating cyclic stress under normal operating condition is called "life" of the bearing. Generally, bearing life is defined by total number of rotation of the bearing until flaking is generated on track surface. However, recognizing average life as criteria of bearing life is not appropriate for actual selection of bearing since fatigue limit of material varies. It shall be practical to consider the life guaranteed to most bearings (basic rating life) as a criterion. Phenomenon that bearing becomes inoperative due to heat-seizure, wear, fracture, scoring are regarded as "failure" caused by operating conditions and selection of bearing so that they and the life should be considered as different phenomena.

## 1-2 Basic rating life

Basic rating life of bearing shall be defined as a total number of rotation that 90% of the group of the same bearings can run without causing flaking due to rolling fatigue when they are operated under the same conditions.

In the case of rotation in certain constant speed, the basic rating life can be expressed in a total rotation time as well.

## 1-3 Basic dynamic load rating

A given static radial load under which a bearing theoretically endures basic rating life of one million rotations is referred to as a basic dynamic load rating.

## 1-4 Dynamic equivalent load

### Dynamic equivalent radial load

A load that is virtually applied to the center of a bearing under which to obtain a life equivalent to that when both radial load and axial load are subjected to the bearing at the same time is called the dynamic equivalent radial load. In the case of needle bearing, its radial type is capable for loading radial load only so that just a radial load will be applied.

## 1-5 Bearing life calculation formula

The following relationship is applied to basic rating life, basic dynamic load rating and dynamic equivalent load of bearing.

$$L_{10} = (C_r / P_r)^p \dots \dots \dots (1.1)$$

- $L_{10}$  : Basic rating life  $10^6$ rotation
- $C_r$  : Basic dynamic load rating N
- $P_r$  : Dynamic equivalent radial load N
- $p$  : Ball bearing  $p = 10/3$ , Roller bearing  $p = 3$

Basic rating life time can be expressed as total rotation time with given rotation per minute by the following formula.

$$L_h = 10^6 L_{10} / 60n = 500 f_h^p \dots \dots \dots (1.2)$$

$$f_h = f_n C_r / P_r \dots \dots \dots (1.3)$$

$$f_n = (33.3 / n)^{1/p} \dots \dots \dots (1.4)$$

- $L_h$  : Basic rating life expressed in hour h
- $n$  : Rotation per minute rpm
- $f_h$  : Bearing life factor
- $f_n$  : Speed factor

## Basic rating life scale

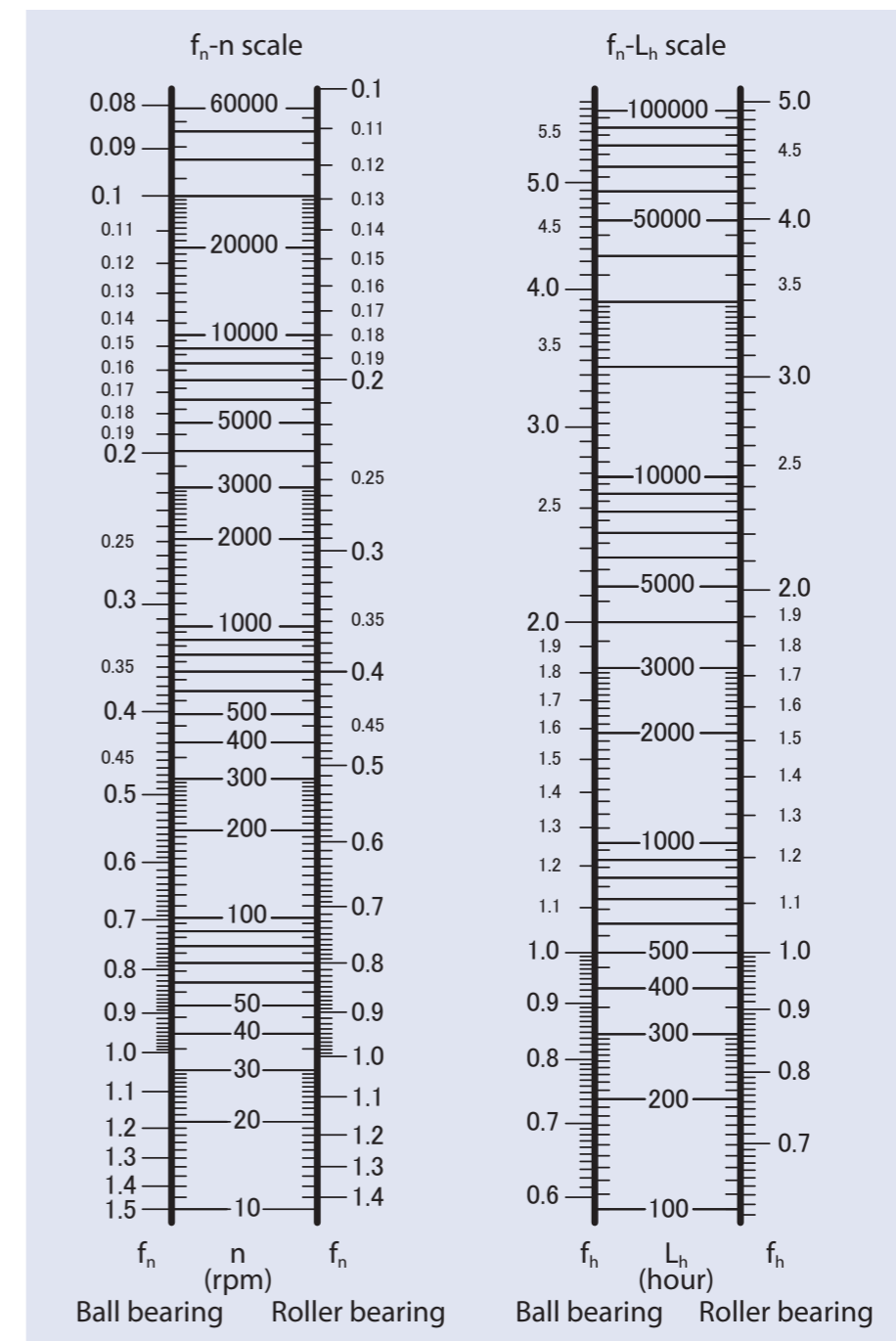

## 1-6 Operating conditions and bearing life factor of bearing

### Operating machinery and demanded life

Bearings should be selected based on setting up demanded life in accordance with operating machinery and operating condition.

Demanded life is determined by endurance duration for operating machinery and reliable operating periods.

Table-1 indicates demanded life that can be a typical reference.

Table-1 Operating condition and demanded life time factor (reference)

Operating conditions	Bearing life factor $f_h$				
	~3	2~4	3~5	4~7	6~
Short duration or occasional operation	Home appliance Electrical tools	Agricultural machinery Office equipment			
Short duration or occasional operation, but necessity for ensuring reliable operation	Medical equipment Measuring instrument	Home air conditioning Construction machinery Crane	Elevator	Crane (sheave wheel)	
Long duration operation but not full time		Small size motor General gear system Woodworking machinery Passenger car	Machine tools Factory general purpose motor Crusher	Important gear system Calendar roller for rubber and plastic Printing machine	
Continuous operation over eight hours a day		Rolling machine Escalator Conveyer Centrifugal separator	Air conditioner Large size motor Compressor, pump	Mine hoist Press machine	Pulp, papermaking machine
Operate 24 hours a day and must be non stop without accident					Water-work system Power generator system

## 1-7 Corrected rating life

Formula for basic rating life described above is applied to bearings whose reliability is 90%, whose material is for general purpose bearing and are manufactured in general quality standard as well as those operated under standard operating conditions. Corrected rating life should be calculated using correction factor  $a_1$ ,  $a_2$  and  $a_3$  in the case that the reliability is over 90% or that life needs to be obtained for special bearing properties or for special operating conditions.

$$L_{na} = a_1 a_2 a_3 L_{10} \dots \dots \dots (1.5)$$

$L_{na}$  : Adjustment rating life  $10^6$  rotation

$a_1$  : Reliability factor

$a_2$  : Bearing special properties factor

$a_3$  : Operating conditions factor

### 1-7-1 Reliability factor

#### Reliability factor $a_1$

This is the bearing life corrected factor for reliability (100-n) % when probability of failure is n %. Value of the reliability factor  $a_1$  is shown in Table-2.

Table-2 Reliability factor  $a_1$

Reliability (%)	$L_n$	$a_1$
90	$L_{10}$	1
95	$L_5$	0.62
96	$L_4$	0.53
97	$L_3$	0.44
98	$L_2$	0.33
99	$L_1$	0.21

### 1-7-2 Bearing special properties factor

#### Bearing special properties factor $a_2$

Bearing special properties factor  $a_2$  is used for adjusting variation of properties concerning life in the case that material type, quality or manufacturing process is special. This factor shall be  $a_2=1$  for standard material and manufacturing method. It can be  $a_2 > 1$  when special modified material or manufacturing method is used due to improved quality of bearing material or progress of manufacturing technology.

### 1-7-3 Operating conditions factor

#### Operating conditions factor $a_3$

This is a factor to adjust impact of operating conditions of bearing, especially effect of lubrication to fatigue life.

Bearing life is essentially a fatigue phenomenon of surface layer which is subjected to repeating cyclic load. Therefore, this factor will be  $a_3=1$  under ideal lubrication condition when rolling element and track surface are completely isolated by oil film and surface failure can be ignored. Under poor lubrication condition such as low lubricant viscosity or under significantly slow rotation speed of rolling element, it would be  $a_3 < 1$ .

On the contrary, it can be  $a_3 > 1$  under especially excellent lubrication condition. Generally, the bearing special properties factor  $a_2$  can not be set to value exceeding 1 when  $a_3 < 1$ .

## 1-8 Adjustment of Basic Dynamic Load Rating for temperature and hardness factors

### 1-8-1 Temperature factor

While operating temperature of bearing is individually defined in accordance with material and structure, bearing is capable to be used at temperatures higher than 150 °C by applying special treatment for thermal resistance. However this will cause reduction of basic dynamic load rating as a result of reduction of permissive contact stress. Basic dynamic load rating with consideration for temperature increase is given by the following formula.

$$C_1 = f_1 C_r \dots\dots\dots (1.6)$$

- $C_1$  : Basic dynamic load rating with consideration for temperature increase N
- $f_1$  : Temperature factor (Refer to Figure-1)
- $C_r$  : Basic dynamic load rating N

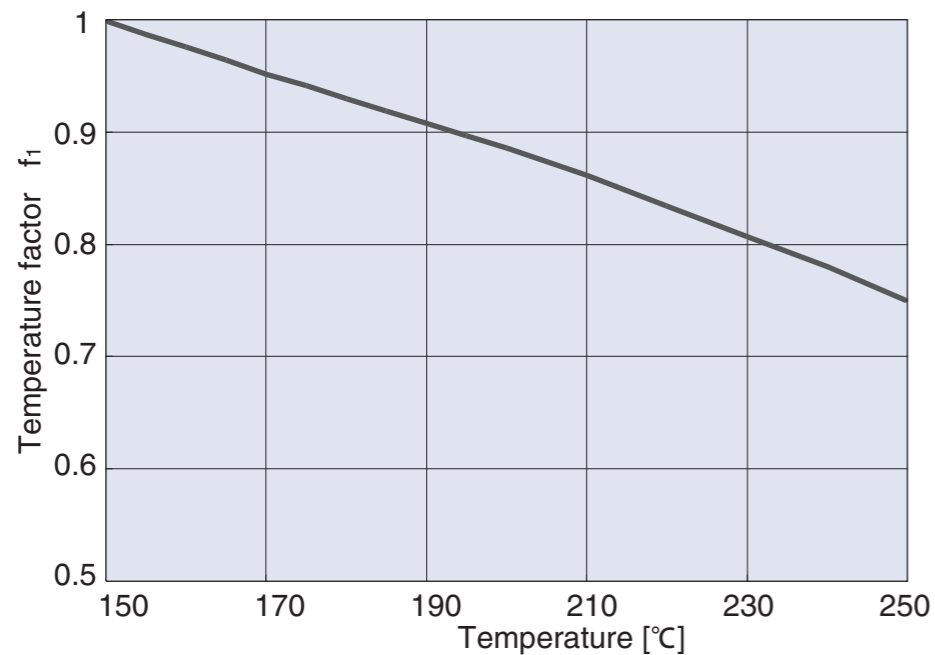

Figure-1

### 1-8-2 Hardness factor

The raceway surface should be HRC58 to 64 in the case of using shaft or housing as raceway instead of bearing inner ring or outer ring respectively. Basic dynamic load rating may be reduced in the case the surface hardness is lower than HRC58. Basic dynamic load rating with consideration for surface hardness is given by the following formula.

$$C_2 = f_2 C_r \dots\dots\dots (1.7)$$

- $C_2$  : Basic dynamic load rating with consideration for hardness N
- $f_2$  : Hardness factor (Refer to Figure-2)
- $C_r$  : Basic dynamic load rating N

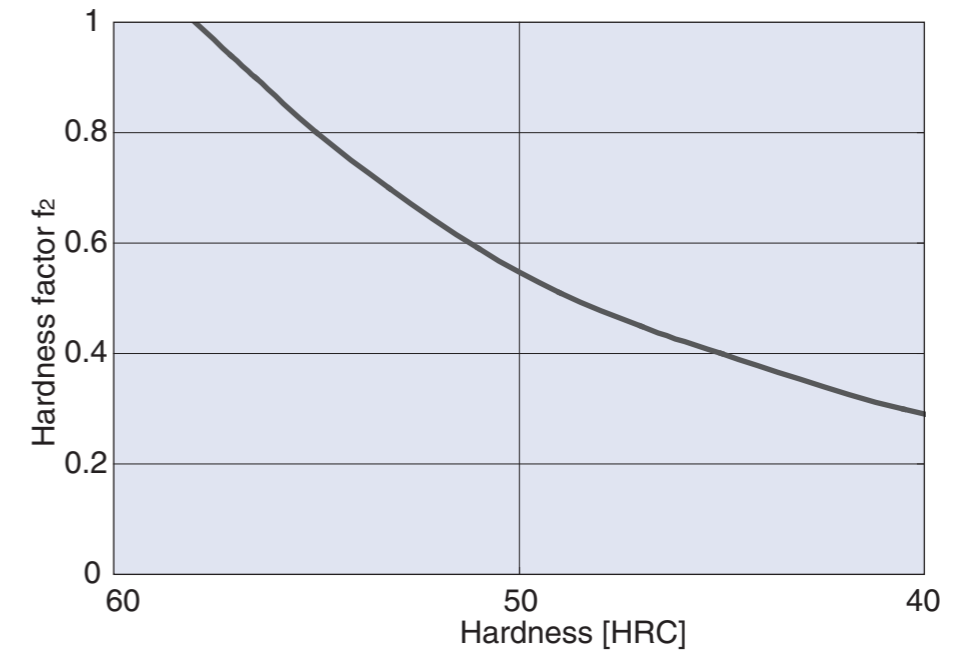

Figure-2

### 1-9 Basic static load rating

Basic static load rating is specified as a static load which corresponds to contact stress indicated in the table below at rolling element and the center of contact of track that are subjected to the maximum load. Total permanent deformation of rolling element and track occurred by the contact stress may be approximately 0.0001 times of diameter of the rolling element.

Type of bearing	Contact stress MPa
Roller bearing	4000



## 1-10 Static equivalent load

A load that is virtually applied to the center of a bearing under which to obtain a contact stress equivalent to the maximum contact stress that occurs at contact surface between rolling element and track, when both radial load and axial load are subjected to the bearing at the same time, is called a static equivalent load.

In the case of needle bearing, its radial type is capable for loading radial load only so that just a radial load will be applied.

$$P_{Or} = F_r \dots\dots\dots (1.8)$$

$P_{Or}$  : Static equivalent radial load N

## 1-11 Static safety factor

Although permissive limit of static equivalent load is typically regarded as basic static load rating, its limit shall be set with consideration for safety since conditions required for bearings broadly vary. The static safety factor  $f_s$  is given by the following formula (1.9). Table-3 shows its typical values.

$$f_s = \frac{C_{Or}}{P_{Or}} \dots\dots\dots (1.9)$$

$f_s$  : Safety factor

$C_{Or}$  : Basic static load rating N

Table-3 Static safety factor

Operating conditions of bearing	$f_s$
With high rotation accuracy With impact load	$\geq 3$
With standard rotation accuracy	$\geq 1.5$
With standard rotation accuracy and low speed	$\geq 1$

## 1-12 Permissive rotation speed

Increasing bearing rotation speed may cause a rise in bearing temperature due to abrasion heat generated inside of the bearing, which results in failure with heat-seizure. A threshold rotation speed up to which long duration of safe operation is enabled is referred to as a permissive rotation speed.

Permissive rotation speed varies depending on type, size and load of bearing, lubrication method and its radial clearance. It is an experimental value at which operation is enabled without causing heat generation exceeding certain limit.

# 2 Bearing load

## 2-1 Load factor

Operation in actual machinery is subjected to a load larger than theoretical axial directional load due to vibration and impact shock.

Actual load is given by calculation of load applied to axes system using load factor shown in Table-4.

$$K = f_w \cdot K_c \dots\dots\dots (2.1)$$

$K$  : Actual load applied to axes system N

$K_c$  : Theoretical calculation value N

$f_w$  : Load factor (Table-4)

Table-4 Load factor

Degree of load	Examples	$f_w$
Smooth motion without any impacts	Air conditioner, measurement instruments, office equipment	1 ~1.2
With standard rotation	Gear box, vehicle, paper-making machine	1.2~1.5
Operation with vibration and impact shock	Rolling machine, construction machinery, crusher	1.5~3

## 2-2 Load distribution

### Load distribution to bearing

Axes system is assumed as a static beam supported by bearings in order to distribute load acting on the axes system to the bearings. Table-5 shows calculation example of load distribution.

Table-5 Example of calculation of load distribution

Examples	Load calculation
	$F_1 = \frac{W_1(b+c) + W_2c}{a+b+c}$ $F_2 = \frac{W_1a + W_2(a+b)}{a+b+c}$
	$F_1 = \frac{W_1(a+b+c) + W_2c}{b+c}$ $F_2 = \frac{W_2b - W_1a}{b+c}$

## 2-3 Load transmission

### Bearing loads in belt or chain transmission

The force acting on pulley or sprocket wheel when power is transmitted by a belt or chain is given by the following formula.

$$T = 9550P/N \dots\dots\dots (2.2)$$

$$F_t = 2000 \cdot T/d \dots\dots\dots (2.3)$$

- T** : Torque acting on pulley or sprocket wheel N·m
- F<sub>t</sub>** : Effective force transmitted by belt or chain N
- P** : Transmitted power kW
- N** : Rotation per minute rpm
- d** : Effective diameter of pulley or sprocket wheel mm

Load  $F_r$  acting on pulley shaft is given by multiplying effective transmitted force  $F_t$  by belt factor  $f_b$  shown in Table-6 in the case of belt transmission.

$$F_r = f_b F_t \dots\dots\dots (2.4)$$

Table-6 Belt factor

Type of belt	$f_b$
V belt	2 ~2.5
Flat belt (with tension pulley)	2.5~3
Flat belt (without tension pulley)	4 ~5

In the case of chain transmission, load acting on sprocket wheel shaft is given by the formula (2.4) as same as that of belt transmission using value between 1.2 and 1.5 as chain factor corresponding to  $f_b$ .

### Bearing loads in gear transmission

In the case of power transmission by gear, methods of calculation vary depending on the type of gear since force acting on the gear is divided into radial load and axial load and their direction and ratio vary depending on the type of gear. In the case of the simplest flat gear, direction of load is radial load only and it is given by the following formula.

$$T = 9550P/N \dots\dots\dots (2.5)$$

$$F_t = 2000 \cdot T/d \dots\dots\dots (2.6)$$

$$F_r = Ft \cdot \tan \alpha \dots\dots\dots (2.7)$$

$$F_c = \sqrt{F_t^2 + F_r^2} \dots\dots\dots (2.8)$$

- T** : Torque acting on gear N·m
- F<sub>t</sub>** : Force in tangent direction of gear N
- F<sub>r</sub>** : Force in radial direction of gear N
- F<sub>c</sub>** : Combine force acting perpendicular to gear N
- P** : Transmitted power kW
- N** : Rotation per minute rpm
- d** : Pitch circle diameter of drive gear mm
- α** : Pressure angle of gear

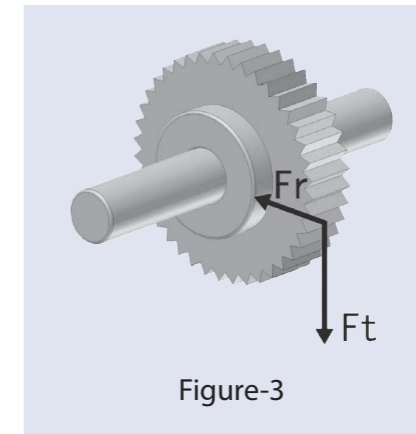

Value that is given by multiplying theoretical load by gear factor  $f_z$  in Table-7 shall be used as actual load since degree of vibration and impact shock affecting the theoretical load obtained by the formula above varies depending on the type of gear and accuracy of gear surface finish.

$$F = f_z F_c \dots\dots\dots (2.9)$$

Table-7 Gear factor

Type of gear	$f_z$
Precision gear (Both of pitch error and geometric error is 0.02 mm or less)	1.05~1.1
Ordinary machined gear (Both of pitch error and geometric error is between 0.02 mm and 0.1 mm)	1.1 ~1.3

### Average load

Average load  $F_m$  which is converted so as to apply even life to each bearing may be used in the case that load acting on bearing is unstable and changes in various cycle.

#### (1) Fluctuating step load

Average load  $F_m$  is given by formula (2.10) in the case that bearing load  $F_1, F_2, F_3 \dots$  is applied with rotation speed and operation duration of  $n_1, n_2, n_3 \dots$  and  $t_1, t_2, t_3 \dots$  respectively.

$$F_m = \left[ \frac{(F_1^{10/3} \cdot n_1 t_1 + F_2^{10/3} \cdot n_2 t_2 + \dots + F_n^{10/3} \cdot n_n t_n)}{(n_1 t_1 + n_2 t_2 + \dots + n_n t_n)} \right]^{3/10} \dots \dots \dots (2.10)$$

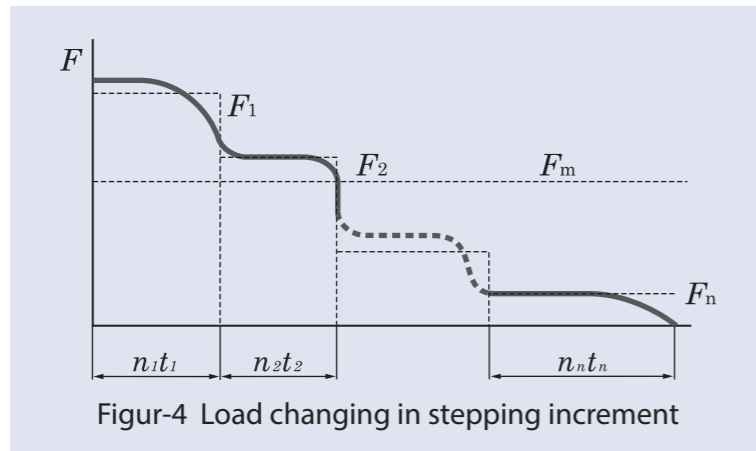

#### (2) Continuously fluctuating load

Average load is given by formula (2.11) in the case that the load can be expressed in function  $F(t)$  of time  $t$  with cycle  $t_0$ .

$$F_m = \left[ \frac{1}{t_0} \int_0^{t_0} F(t)^{10/3} dt \right]^{3/10} \dots \dots \dots (2.11)$$

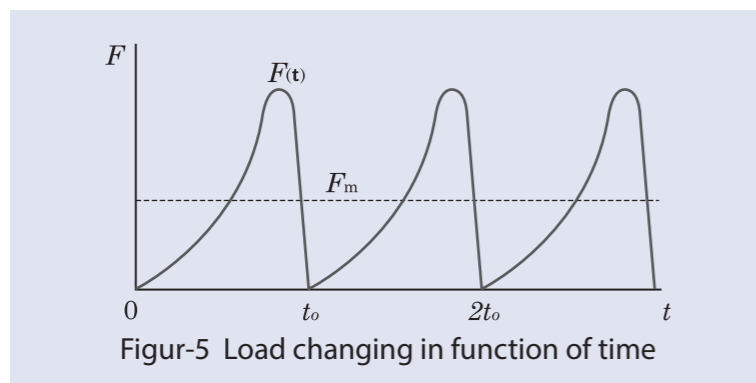

#### (3) Roughly linear load

Average load  $F_m$  is approximately given by formula (2.12).

$$F_m = \frac{F_{min} + 2F_{max}}{3} \dots \dots \dots (2.12)$$

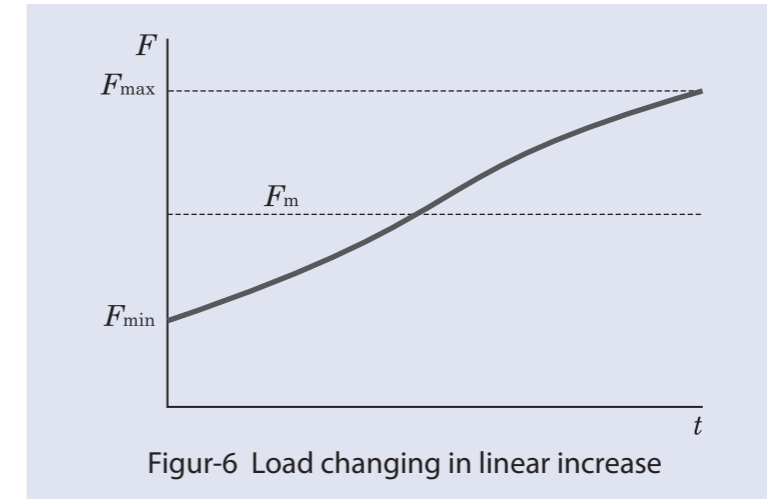

#### (4) Sinusoidal fluctuating load

Average load  $F_m$  is approximately given by formula (2.13) and formula (2.14).

$$(a): F_m = 0.75 F_{max} \dots \dots \dots (2.13)$$

$$(b): F_m = 0.65 F_{max} \dots \dots \dots (2.14)$$

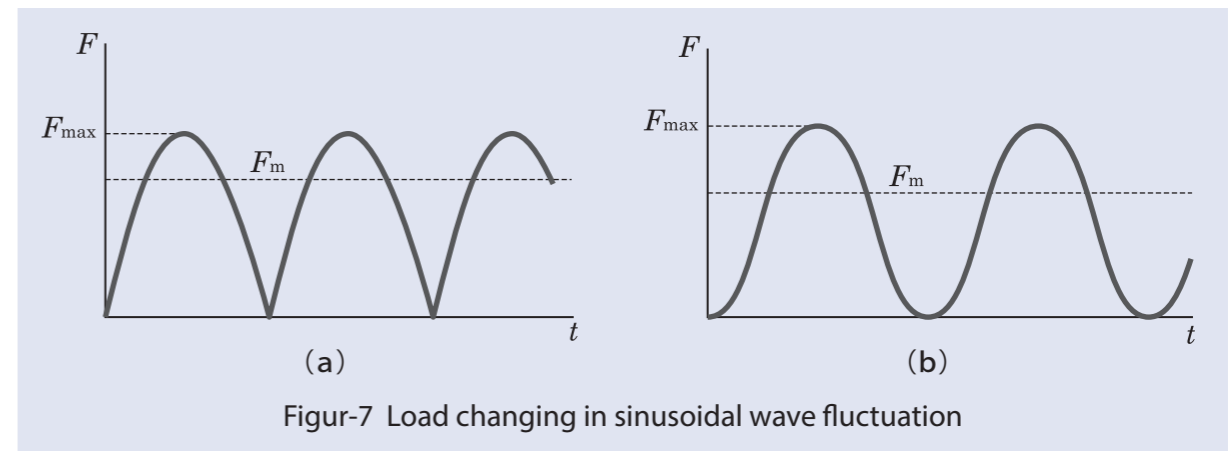

### 3 Bearing accuracy

#### 3-1 Accuracy

Dimensional accuracy, geometrical accuracy and rotation accuracy of bearing are specified in ISO standards and JIS B 1514 (Rolling bearings - Tolerances of bearings).

Accuracy class of needle bearing is specified by four classes from lowest class 0 to 6th, 5th and 4th class in the highest. While high accuracy bearing in 5th or 4th class may be used in application for the case high rotation accuracy is demanded or high speed rotation, class 0 is used in most of general purpose application.

Table-8 Accuracy of inner ring

Unit:  $\mu\text{m}$

d Nominal bearing bore diameter (mm)		$\Delta_{dmp}$ Deviation of mean bore diameter in a single plane								$V_{dsp}$ Variation of bore diameter in a single plane				$V_{dmp}$ Variation of mean bore diameter in a single plane				$K_{ia}$ Radial runout of inner ring of assembled bearing				$S_d$ Reference face runout with bore (Inner ring)		$\Delta_{Bs}$ Deviation of a single inner ring width				$V_{Bs}$ Variation of inner rings width				d Nominal bearing bore diameter (mm)			
		0		6		5		4		0		6		5		4		0		6		5		4		0,6		5,4		0				6	
Over	Incl.	high	low	high	low	high	low	high	low	max.				max.				max.				max.		high	low	high	low	max.				Over	Incl.		
2.5 <sup>1)</sup>	10	0	-8	0	-7	0	-5	0	-4	10	9	5	4	6	5	3	2	10	6	4	2.5	7	3	0	-120	0	-40	15	15	5	2.5	2.5 <sup>1)</sup>	10		
10	18	0	-8	0	-7	0	-5	0	-4	10	9	5	4	6	5	3	2	10	7	4	2.5	7	3	0	-120	0	-80	20	20	5	2.5	10	18		
18	30	0	-10	0	-8	0	-6	0	-5	13	10	6	5	8	6	3	2.5	13	8	4	3	8	4	0	-120	0	-120	20	20	5	2.5	18	30		
30	50	0	-12	0	-10	0	-8	0	-6	15	13	8	6	9	8	4	3	15	10	5	4	8	4	0	-120	0	-120	20	20	5	3	30	50		
50	80	0	-15	0	-12	0	-9	0	-7	19	15	9	7	11	9	5	3.5	20	10	5	4	8	5	0	-150	0	-150	25	25	6	4	50	80		
80	120	0	-20	0	-15	0	-10	0	-8	25	19	10	8	15	11	5	4	25	13	6	5	9	5	0	-200	0	-200	25	25	7	4	80	120		
120	150	0	-25	0	-18	0	-13	0	-10	31	23	13	10	19	14	7	5	30	18	8	6	10	6	0	-250	0	-250	30	30	8	5	120	150		
150	180	0	-25	0	-18	0	-13	0	-10	31	23	13	10	19	14	7	5	30	18	8	6	10	6	0	-250	0	-250	30	30	8	5	150	180		
180	250	0	-30	0	-22	0	-15	0	-12	38	28	15	12	23	17	8	6	40	20	10	8	11	7	0	-300	0	-300	30	30	10	6	180	250		
250	315	0	-35	0	-25	0	-18	—	—	44	31	18	—	26	19	9	—	50	25	13	—	13	—	0	-350	0	-350	35	35	13	—	250	315		

1) 2.5 mm is included in this dimension group

Table-9 Accuracy of outer ring

Unit:  $\mu\text{m}$

D Nominal bearing outside diameter (mm)		$\Delta_{Dmp}$ Deviation of mean outside diameter in a single plane								$V_{Dsp}$ Variation of outside diameter in a single plane				$V_{Dmp}$ Variation of mean outside diameter in a single plane				$K_{ea}$ Radial runout of outer ring of assembled bearing				$S_D$ Variation of outside surface generatrix inclination with face (outer ring)		$\Delta_{Cs}$ Deviation of a single outer ring width				$V_{Cs}$ Variation of outer ring width				D Nominal bearing outside diameter (mm)	
		0		6		5		4		0		6		5		4		0		6		5		4		0,6,5,4		0		6			
Over	Incl.	high	low	high	low	high	low	high	low	max.				max.				max.				max.		high	low	max.				Over	Incl.		
2.5 <sup>2)</sup>	6	0	-8	0	-7	0	-5	0	-4	10	9	5	4	6	5	3	2	15	8	5	3	8	4	Depending on tolerance of $\Delta_{Bs}$ for D of the same bearing.	high	low	Depending on tolerance of $V_{Bs}$ for D of the same bearing.	5	2.5	2.5 <sup>2)</sup>	6		
6	18	0	-8	0	-7	0	-5	0	-4	10	9	5	4	6	5	3	2	15	8	5	3	8	4					5	2.5	6	18		
18	30	0	-9	0	-8	0	-6	0	-5	12	10	6	5	7	6	3	2.5	15	9	6	4	8	4					5	2.5	18	30		
30	50	0	-11	0	-9	0	-7	0	-6	14	11	7	6	8	7	4	3	20	10	7	5	8	4					5	2.5	30	50		
50	80	0	-13	0	-11	0	-9	0	-7	16	14	9	7	10	8	5	3.5	25	13	8	5	8	4					6	3	50	80		
80	120	0	-15	0	-13	0	-10	0	-8	19	16	10	8	11	10	5	4	35	18	10	6	9	5					8	4	80	120		
120	150	0	-18	0	-15	0	-11	0	-9	23	19	11	9	14	11	6	5	40	20	11	7	10	5					8	5	120	150		
150	180	0	-25	0	-18	0	-13	0	-10	31	23	13	10	19	14	7	5	45	23	13	8	10	5					8	5	150	180		
180	250	0	-30	0	-20	0	-15	0	-11	38	25	15	11	23	15	8	6	50	25	15	10	11	7					10	7	180	250		
250	315	0	-35	0	-25	0	-18	0	-13	44	31	18	13	26	19	9	7	60	30	18	11	13	8					11	7	250	315		

2) 2.5 mm is included in this dimension group



Table-10 Permissive tolerance of chamfer Unit: mm

$r_s$ min	d Nominal bearing bore diameter		Radial direction	Axial direction
	Over	Incl.	$r_s$ max	
0.15	—	—	0.3	0.6
0.2	—	—	0.5	0.8
0.3	— 40	40 —	0.6 0.8	1 1
0.6	— 40	40 —	1 1.3	2 2
1	— 50	50 —	1.5 1.9	3 3
1.1	— 120	120 —	2 2.5	3.5 4
1.5	— 120	120 —	2.3 3	4 5
2	— 80 220	80 220 —	3 3.5 3.8	4.5 5 6
2.1	— 280	280 —	4 4.5	6.5 7
2.5	— 100 280	100 280 —	3.8 4.5 5	6 6 7
3	— 280	280 —	5 5.5	8 8
4	—	—	6.5	9

\* Remark Although no particular shape is specified for chamfer surface, its outline in axial plane must be within virtual arc of  $r_s$  min radius that is tangent to slope of inner ring and inner diameter face of bearing, or tangent to side of outer ring and bearing outer diameter. (Reference diagram)

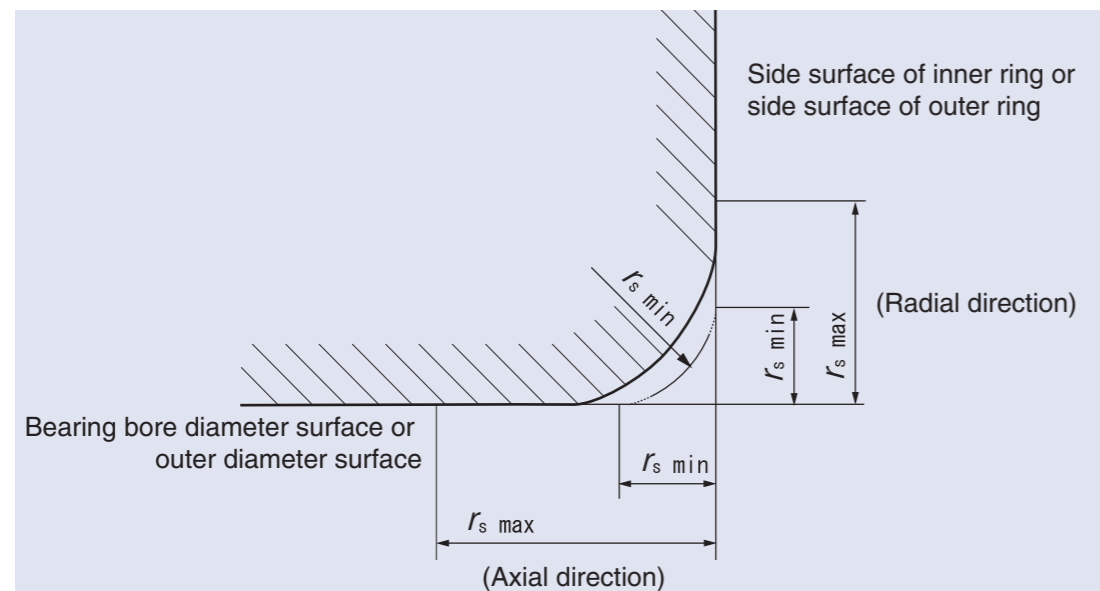

Table-11 Tolerance of minimum value of diameter of inscribed circle to roller Unit:  $\mu$ m

$F_w$ (mm) Inscribed circle diameter		Dimension difference of $\Delta F_w$ min Variation of minimum value of diameter of inscribed circle to roller	
Over	Incl.	high	low
3	6	+18	+10
6	10	+22	+13
10	18	+27	+16
18	30	+33	+20
30	50	+41	+25
50	80	+49	+30
80	120	+58	+36
120	180	+68	+43
180	250	+79	+50
250	315	+88	+56

This means diameter of roller that achieves zero radial clearance in at least one radial direction in the case of using cylindrical roller instead of bearing inner ring.

### 3-2 Measurement method

#### Measurement of single bore diameter

Table-12 Bearing bore diameter

Type and definition of accuracy	
$d_{mp}$ Mean bore diameter in a single plane	Arithmetic mean of maximum and minimum value of the single bore diameters in a single radial plane. $d_{mp} = \frac{d_{sp\ max} + d_{sp\ min}}{2}$ $d_{sp}$ : Single inner diameter in a particular radial plane.
$\Delta_{dmp}$ Deviation of mean bore diameter in a single plane	Difference between the mean bore diameter and nominal bore diameter. $\Delta_{dmp} = d_{mp} - d$ $d$ : Nominal bearing bore diameter.
$V_{dsp}$ Variation of single bore diameter in a single plane	Difference between maximum and minimum value of single bore diameter in single radial plane. $V_{dsp} = d_{sp\ max} - d_{sp\ min}$
$V_{dmp}$ Variation of mean bore diameter in a single plane	Difference between maximum and minimum value of the mean bore diameter in a single plane in individual track ring basically with cylindrical inner diameter face. $V_{dmp} = d_{mp\ max} - d_{mp\ min}$
$\Delta_{ds}$ deviation of single bore diameter	Difference between single bore diameter and nominal bore diameter. $\Delta_{ds} = d_s - d$ $d_s$ : Distance between two parallel straight lines which are tangent to intersecting line of actual bore diameter face and radial plane.

Method of measurement of bearing bore diameter

Zero the gauge indicator to the appropriate size using gauge blocks or a master ring.  
In several angular directions and in a single radial plane, measure and record the largest and the smallest single bore diameters,  $d_{sp\ max}$  and  $d_{sp\ min}$ .  
Repeat angular measurements and recordings in several radial planes to determine the largest and the smallest single bore diameter of an individual ring,  $d_{s\ max}$  and  $d_{s\ min}$ .

Table-13 Measurement area limit Unit: mm

$r_s\ min$		a
Over	or less	
-	0.6	$r_{s\ max} + 0.5$
0.6	-	$1.2 \times r_{s\ max}$

#### Measurement of single outside diameter

Table-14 Bearing outer diameter

Type and definition of accuracy	
$D_{mp}$ mean outside diameter in a single plane	Arithmetic mean of maximum and minimum value of the single outside diameters in a single radial plane. $D_{mp} = \frac{D_{sp\ max} + D_{sp\ min}}{2}$ $D_{sp}$ : Single outside diameter in a particular radial plane
$\Delta_{Dmp}$ Deviation of mean outside diameter in a single plane	Difference between the mean outside diameter in a single plane of cylindrical outside diameter face and nominal outside diameter. $\Delta_{Dmp} = D_{mp} - D$ $D$ : Nominal bearing outside diameter.
$V_{Dsp}$ deviation of single outside diameter	Difference between maximum and minimum value of the mean outside diameter in a single radial plane. $V_{Dsp} = D_{sp\ max} - D_{sp\ min}$
$V_{Dmp}$ Variation of mean outside diameter in a single plane	Difference between maximum and minimum value of the mean outside diameter in a single plane in individual track ring with basically cylindrical outer diameter face. $V_{Dmp} = D_{mp\ max} - D_{mp\ min}$
$\Delta_{Ds}$ deviation of single bore diameter	Difference between single outside diameter in basically cylindrical outside diameter face and nominal outside diameter. $\Delta_{Ds} = D_s - D$ $D_s$ : Distance between two parallel straight lines which are tangent to intersecting line of actual outer diameter face and radial plane.

Method of measurement of bearing outer diameter

Zero the gauge indicator to the appropriate size using gauge blocks or a master.  
In several angular directions and in a single radial plane, measure and record the largest and the smallest single outside diameters,  $D_{sp\ max}$  and  $D_{sp\ min}$ .  
Repeat and record measurements in several radial planes to determine the largest and the smallest single outside diameter of an individual ring,  $D_{s\ max}$  and  $D_{s\ min}$ .

## Measurement of single bore diameter of rolling element complement

Table-15 Measurement of single bore diameter of rolling element complement

Type and definition of accuracy	
$F_{ws}$ Nominal bore diameter of rolling element complement	Distance between two parallel straight lines which are tangent to intersecting line of inscribed circle of rolling element complement and radial plane in radial bearing without inner ring.
$F_{ws\ min}$ Minimum nominal bore diameter of rolling element complement	Minimum nominal bore diameter of rolling element complement in radial bearing without inner ring.  Remark Minimum nominal bore diameter of rolling element complement is diameter of cylinder whose radial clearance becomes zero in at least one radial direction.

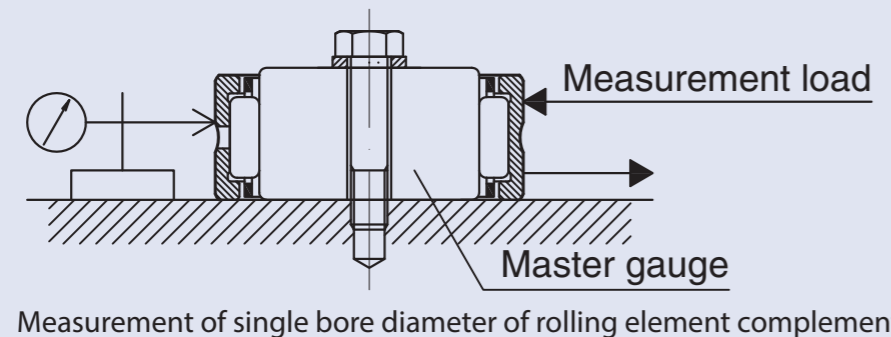

Fasten the master gauge to a surface plate.

Position the bearing on the master gauge and apply the indicator in the radial direction to the approximate middle of the width on the ring outside surface.

Measure the amount of movement of the outer ring in the radial direction by applying sufficient load on the outer ring in the same radial direction as that of the indicator and in the opposite radial direction.

Record indicator readings at the extreme radial positions of the outer ring. Rotate the bearing and repeat the measurement in several different angular positions to determine the largest and the smallest readings,  $F_{ws\ max}$  and  $F_{ws\ min}$ .

Table-16 Radial measurement load

$F_w$ mm		Measurement load N
Over	Incl.	min.
—	30	50
30	50	60
50	80	70
80	—	80

## Measurement of single inner ring width (or outer ring width)

Table-17 Measurement of single inner ring width (or outer ring width)

Type and definition of accuracy	
$\Delta_{Bs}$ Deviation of single inner ring width	Difference between single inner ring width and nominal inner ring width. $\Delta_{Bs} = B_s - B$
$V_{Bs}$ Variation of inner ring width	Difference between maximum and minimum value of the single bore diameter width in each inner ring. $V_{Bs} = B_{s\ max} - B_{s\ min}$
$\Delta_{Cs}$ Deviation of single outer ring width	Difference between single outer ring width and nominal outer ring width $\Delta_{Cs} = C_s - C$
$V_{Cs}$ Variation of outer ring width	Difference between maximum and minimum value of the single outer ring width in each outer ring. $V_{Cs} = C_{s\ max} - C_{s\ min}$

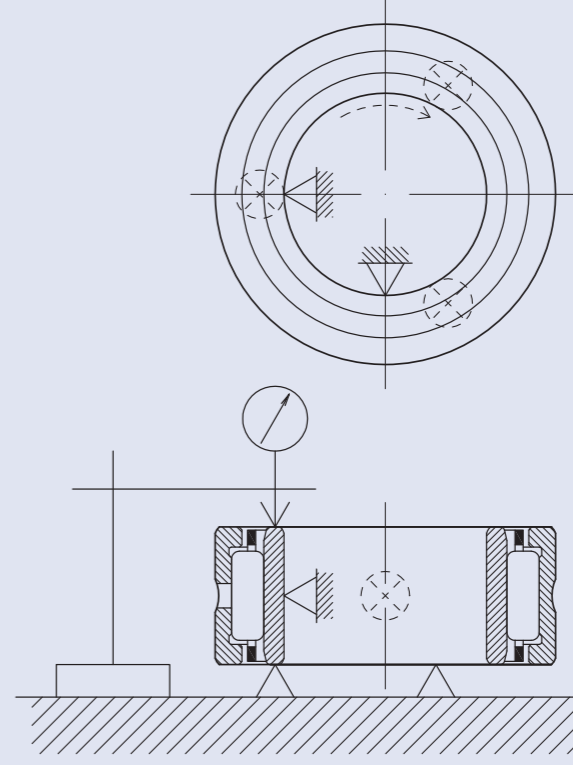

Zero the gauge indicator to the appropriate height from the reference surface using gauge blocks or a master.

Support one face of the ring on three equally spaced fixed supports of equal height and provide two suitable radial supports on the bore surface set at 90° to each other to center the ring.

Position the indicator against the other face of the ring opposite one fixed support.

Rotate the ring one revolution and measure and record the largest and the smallest single ring width,  $B_{s\ max}$  and  $B_{s\ min}$  ( $C_{s\ max}$  and  $C_{s\ min}$ ).

### Measurement of perpendicularity of inner ring face with respect to the bore ( $S_d$ )

Use a precision arbor having a taper of approximately 1:5000 on diameter.

Mount the bearing assembly on the tapered arbor and place the arbor between two centres so that it can be accurately rotated.

Position the indicator against the reference face of the inner ring at a radial distance from the arbor axis of half the mean diameter of the face.

Take indicator readings while rotating the inner ring one revolution.

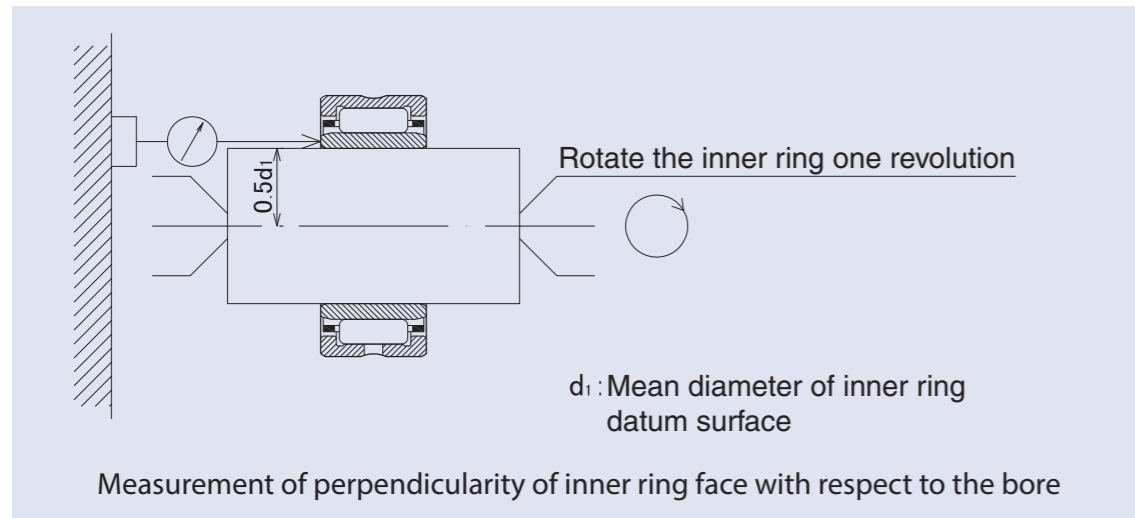

### Measurement of perpendicularity of outer ring outside surface with respect to the face ( $S_D$ )

Support the reference face of the outer ring on a surface plate leaving the inner ring, if an assembled bearing, free. Locate the outer ring cylindrical outside surface against two supports set at 90° to each other to centre the outer ring.

Position the indicator directly above one support. The indicator and the two supports are axially located at the extremes of the measurement zone.

Take indicator readings while rotating the outer ring one revolution.

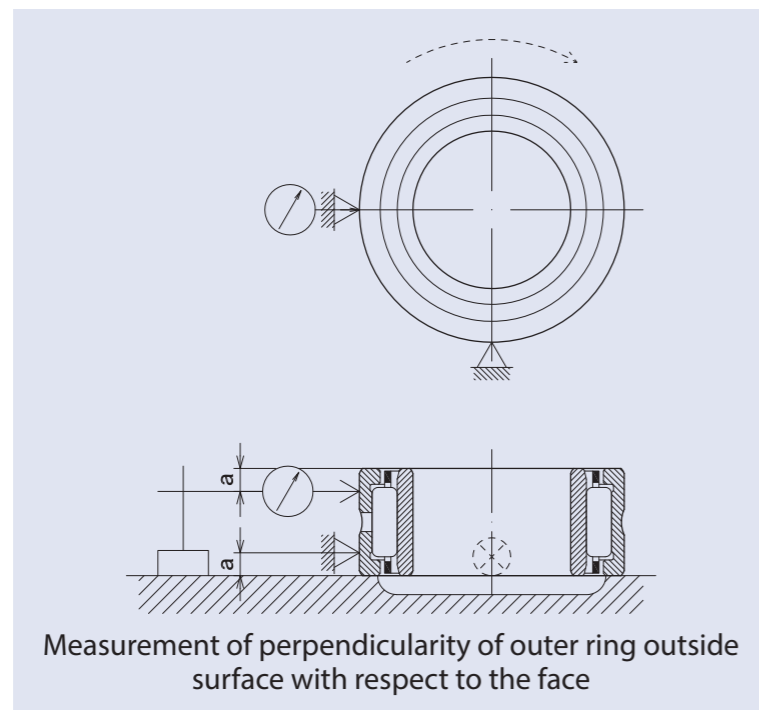

### Measurement of radial runout of inner ring ( $K_{ia}$ )

Use a precision arbor having a taper of approximately 1:5000 on diameter.

Mount the bearing assembly on the tapered arbor and place the arbor between two centres so that it can be accurately rotated.

Position the indicator against the outside surface of the outer ring as close as possible to the middle of the outer ring raceway.

Hold the outer ring to prevent rotation but ensure its weight is supported by the rolling elements. Take indicator readings while rotating the arbor one revolution.

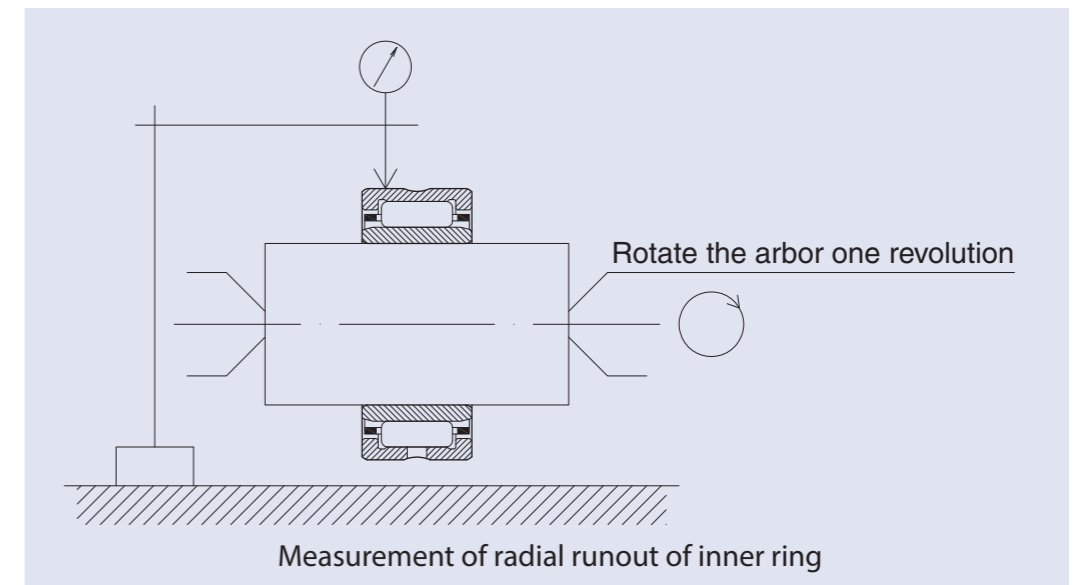

### Measurement of radial runout of outer ring ( $K_{ea}$ )

Use a precision arbor having a taper of approximately 1:5000 on diameter.

Mount the bearing assembly on the tapered arbor and place the arbor between two centres so that it can be accurately rotated.

Position the indicator against the outside surface of the outer ring as close as possible to the middle of the outer ring raceway.

Hold the inner ring stationary. Take indicator readings while rotating the outer ring one revolution.

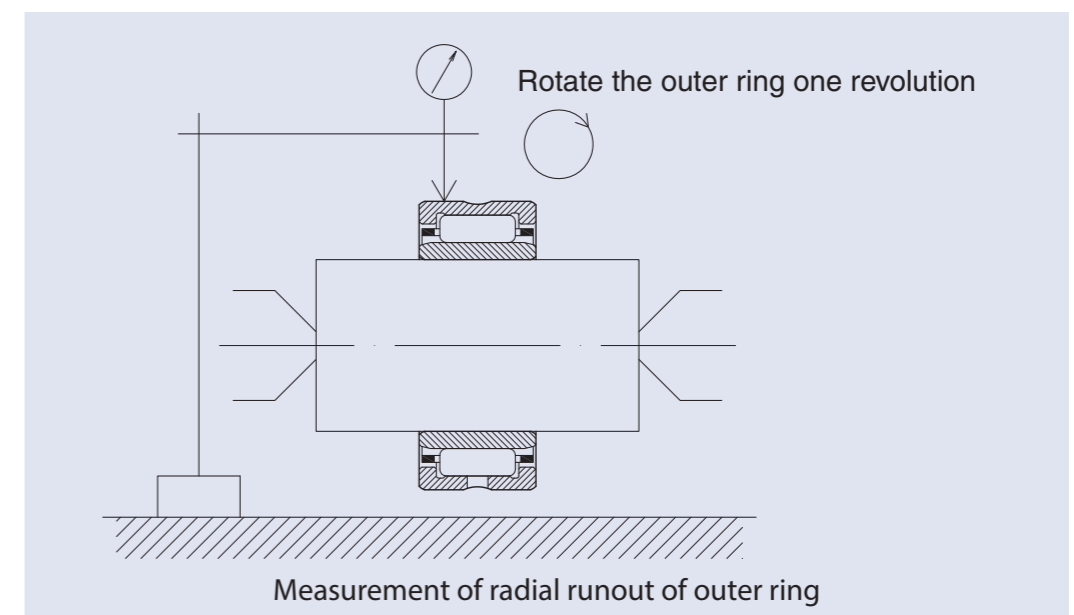

## 4 Internal clearance of bearing

### 4-1 Radial internal clearance of bearing

Radial internal clearance of bearing means a displacement of either inner ring or outer ring, which is free side, when the specified measurement load is applied to it alternatively in radial direction while locking the opposite component in the condition before mounting the bearing on shaft or housing. This measurement loads are quite small and they are specified in JIS B 1515:2006 (Rolling bearings - Tolerances). Radial internal clearance of needle bearing with inner ring is specified in JIS B 1520:1995 (radial internal clearance of bearing). Clearances shown in Table-18 are categorized in group C2, CN, C3, C4, C5 starting from smaller clearance and group CN is applied to general application.

#### ■ Radial internal clearance of bearing

Table-18 Internal clearance of radial bearing

Category	Description
C2	Radial clearance smaller than standard clearance
CN clearance	Standard radial clearance
C3, C4, C5	Radial clearance larger than standard clearance

Table-19 Value of radial internal clearance of needle bearing

Unit:  $\mu\text{m}$

d Nominal bearing bore diameter (mm)		Clearance category									
		C2		CN		C3		C4		C5	
Over	Incl.	min.	max.	min.	max.	min.	max.	min.	max.	min.	max.
-	10	0	25	20	45	35	60	50	75	-	-
10	24	0	25	20	45	35	60	50	75	65	90
24	30	0	25	20	45	35	60	50	75	70	95
30	40	5	30	25	50	45	70	60	85	80	105
40	50	5	35	30	60	50	80	70	100	95	125
50	65	10	40	40	70	60	90	80	110	110	140
65	80	10	45	40	75	65	100	90	125	130	165
80	100	15	50	50	85	75	110	105	140	155	190
100	120	15	55	50	90	85	125	125	165	180	220
120	140	15	60	60	105	100	145	145	190	200	245
140	160	20	70	70	120	115	165	165	215	225	275
160	180	25	75	75	125	120	170	170	220	250	300
180	200	35	90	90	145	140	195	195	250	275	330
200	225	45	105	105	165	160	220	220	280	305	365
225	250	45	110	110	175	170	235	235	300	330	395

Remark Nominal number C2,C3,C4 are displayed as part code suffix for these bearings (excluding CN clearance). Example) NA 4903 C2

### 4-2 Selection of radial internal clearance of bearing

#### Selection of clearance

Radial internal clearance of needle bearing in operation may generally becomes smaller than initial radial internal clearance. Temperature difference between inner and outer bearing during operation and fit cause this change. The radial internal clearance has a significant impact to life, vibration and heat generation of bearing.

Typically, larger radial internal clearance causes increase of vibration and smaller one results in heat generation or reduction of life due to excessive force between rolling element and track. Initial radial internal clearance may be selected as slightly larger than zero clearance in consideration for the internal clearance during operation. Bearing is designed to have suitable radial clearance by selecting CN clearance for general application.

#### Reduction of radial internal clearance due to fits

When bearing is installed to shaft or housing, radial internal clearance reduces due to expansion or shrinking of track with elastic deformation.

#### Reduction of radial clearance due to temperature difference between inner and outer ring

Friction heat generated by rotation of bearing will be released to outside through shaft and/or housing. In general application, radial internal clearance may be reduced as much as the difference of amount of thermal expansion between inner and outer ring since outer ring becomes cooler than inner ring due to larger heat release from housing than that from shaft.



## 5 Fits

### 5-1 Purpose of fits

Purpose of "fits" for a bearing is to fixate a bearing with sufficient "interference" between inner ring and shaft or between outer ring and housing. Insufficient "fits" may cause harmful phenomena which result in damaging bearing or shortening its life such as abnormal wear in fitting surface, abnormal heat by abrasion powder, abnormal rotation and vibration due to slip of fitting surface. Therefore, it is imperative to select proper fits for application.

### 5-2 Selection of fits

#### Condition for selection of fits

Selection of bearing "fits" needs to consider following points. Properties and size of load in application, condition of temperature, accuracy of rotation, material, finish, wall thickness of shaft and housing and easiness of assembling/disassembling.

"Fits" as shown in Table-20 is generally determined based on properties of load and condition of rotation.

Table-20 Properties of radial load and fits

Properties of bearing load			Fits	
			Inner ring	Outer ring
Load with rotating inner ring Load with stationary outer ring		Inner ring: rotation Outer ring: stationary Loading direction: constant	Tight fit	Loose fit
		Inner ring: stationary Outer ring: rotation Loading direction: rotate together with outer ring		
Load with rotating outer ring Load with stationary inner ring		Inner ring: stationary Outer ring: rotation Loading direction: constant	Loose fit	Tight fit
		Inner ring: rotation Outer ring: stationary Loading direction: rotate together with inner ring		
Load in inconsistent direction	Direction of load is inconsistent due to varying load direction or including unbalanced load	Inner ring: rotation or stationary Outer ring: rotation or stationary Loading direction: inconsistent	Tight fit	Tight fit

#### Selection of fits

It is necessary to take condition of temperature and material of shaft and housing into consideration in addition to properties of load and rotation condition for selection of "fits" as mentioned above. Yet, it is common practice to determine "fits" based on reference to experience and past record because of difficulty for recognizing whole conditions. Table-21 and Table-22 show "fits" for general application and Table-23 shows "fits" for needle bearing without inner ring against shaft.

Table-21 Fits between needle bearing and housing hole

Conditions		Tolerance grade for housing
Load with stationary outer ring	Standard and heavy load	J7
	Split housing with standard load	H7
Load in inconsistent direction	Light load	J7
	Standard load	K7
	Heavy load and impact shock load	M7
Load with rotating outer ring	Light load	M7
	Standard load	N7
	Heavy load and impact shock load	P7
Light load and high rotation accuracy		K6

Table-22 Fits between needle bearing with inner ring and shaft

Conditions		Shaft diameter (mm)		Tolerance grade
		Over	Incl.	
Load with rotating inner ring or Load in inconsistent direction	Light load	—	50	j5
		50	100	k5
	Standard load	—	50	k5
		50	150	m5·m6
Heavy load and impact shock load	150~		m6·n6	
	~150		n6·p6	
Load with stationary inner ring	Mid to low speed, light load	All dimension		g6
	Mid to low speed, standard load or heavy load			h6
	With precision rotation accuracy			h5

Remark Light load  $P_r \leq 0.06C_r$  Standard load  $0.06C_r < P_r \leq 0.12C_r$  Heavy load  $P_r > 0.12C_r$   
 $P_r$ : Dynamic equivalent radial load  $C_r$ : Basic dynamic load rating

Table-23 Fits between needle bearing without inner ring and shaft

Nominal diameter of inscribed circle $F_w$ (mm)	Radial internal clearance				
	Clearance smaller than CN clearance	CN clearance	Clearance larger than CN clearance		
	Over	Incl.	Tolerance group grade for shaft		
-	65		k5	h5	g6
65	80		k5	h5	f6
80	160		k5	g5	f6
160	180		k5	g5	e6
180	200		j5	g5	e6
200	250		j5	f6	e6
250	315		h5	f6	e6

Remark Tight fit with housing hole smaller than k7 shall be modified with smaller shaft size in considering diameter shrink of inscribed circle of roller after assembly.



## 6 Design of shaft and housing

### 6-1 Accuracy of fitting surface

Correct design and manufacturing of shaft or housing to which needle bearing is assembled are vital for adequate bearing performance since the needle bearing has thinner track ring compared to other types of rolling bearings. Table-26 shows dimension accuracy and geometric accuracy of "fitting" part of shaft and housing in standard application condition, surface roughness and tolerance of runout of shoulder against fitting surface.

Table-26 Accuracy of shaft and housing (recommended)

Item	Shaft	Housing
Roundness tolerance	IT3~IT4	IT4~IT5
Cylindricity tolerance	IT3~IT4	IT4~IT5
Shoulder runout tolerance	IT3	IT3~IT4
Roughness of fitting surface	0.8a	1.6a

### 6-2 Accuracy of track surface

Needle bearing can be directly attached to shaft or housing as track for compact bearing structure. In this case, accuracy and roughness of track surface must be equivalent to that of bearing track surface in order to ensure bearing life with high rotation accuracy. Since accuracy and roughness of shaft and housing may affect life and the cause of abnormality of the bearing.

Table-27 shows specification for accuracy and roughness of track surface.

Table-27 Accuracy of track surface (recommended)

Item	Shaft	Housing
Roundness tolerance	IT3	IT3
Cylindricity tolerance	IT3	IT3
Shoulder runout tolerance	IT3	IT3
Surface roughness	0.2a	

### 6-3 Material and heat treatment of track surface

Surface hardness of shaft and housing must be HRC58 to 64 in order to obtain sufficient loading capacity in the case of using them as direct track surface. Table-28 shows recommended heat treatment for their material.

Table-28 Material for track

Type of steel	Representative example	Related standards
High carbon-chromium bearing steel	SUJ2	JIS G 4805
Chromium molybdenum steel	SCM415~435	JIS G 4053
Carbon tool steel	SK85	JIS G 4401
Stainless steel	SUS440C	JIS G 4303

### 6-4 Skew of bearing

Skew between inner ring and outer ring generated by deflection of shaft due to external force or mounting error may result in reduction of life caused by abnormal wear or heat. While permissive amount of skew varies depending on type of bearing, load and bearing internal clearance, it is recommended to be 1/2000 or less for general application.

### 6-5 Mounting dimension for bearing

Dimension of shaft and housing for mounting needle bearing (Figure-8) is shown in dimension table for respective bearings.

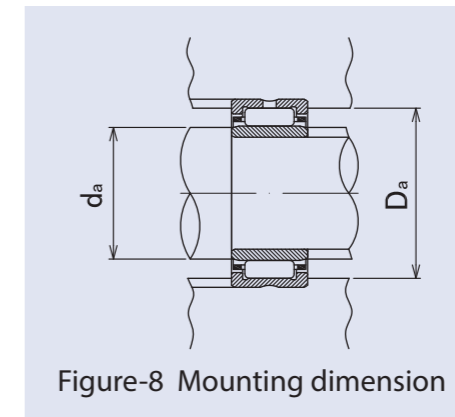

#### Fillet radius and height of shoulder for shaft and housing

Maximum permissive radius ( $r_{as\ max}$ ) of fillet radius for shaft and housing to which needle bearings are assembled corresponds to minimum permissive chamfer dimension ( $r_{s\ min}$ ) of the bearings.

Minimum value of shoulder diameter of the shaft ( $d_a$ ) shall be nominal bore diameter ( $d$ ) of bearing plus its shoulder height ( $h$ ) multiplied by 2. Maximum value of shoulder diameter of the housing ( $D_a$ ) shall be outer diameter ( $D$ ) of bearing minus height of its shoulder multiplied by 2.

Table-29 Maximum permissive actual radius of corner R of shaft and housing  $r_{as\ max}$

Unit: mm

$r_{s\ min}$ Minimum permissive chamfer dimension	$r_{as\ max}$ Maximum permissive actual radius of corner R of shaft and housing
0.1	0.1
0.15	0.15
0.2	0.2
0.3	0.3
0.4	0.4
0.6	0.6
1	1
1.1	1
1.5	1.5
2	2
2.1	2
2.5	2
3	2.5
4	3
5	4

Height of shoulder and corner R

## 7 Lubrication

### 7-1 Purpose of lubrication

Purpose of bearing lubrication is to prevent its heat-seizure by mitigating friction and abrasion of rolling surface and slipping surface. Followings are the detailed explanation.

**(1) Mitigation of friction and abrasion**

It prevents direct contact between track, rolling element and cage.

It also mitigates friction and abrasion as a result of slip on track surface.

**(2) Removal of frictional heat**

Lubricant removes abrasion heat inside of bearing or heat propagated from outside to prevent excessive heat-up of the bearing.

**(3) Extension of bearing life**

Separating rolling element and track by oil film results in extension of bearing life.

**(4) Prevention of rust**

Oil film of lubricant mitigates oxidation inside and surface of bearing to prevent corrosion.

**(5) Prevention of dust**

Packed grease in the case of grease lubrication prevent invasion of foreign matter.

Efficient performance of these effects requires using lubrication method suitable for the application as well as selection of proper lubricant, its adequate amount, prevention against invasion of external foreign matter and optimal sealing structure in order to avoid leakage of the lubricant.

### 7-2 Comparison of grease and oil lubrication

#### Lubrication method

Lubrication method of bearing consists of grease lubrication and oil lubrication.

Grease lubrication is so popular for broad type of bearing because of its cost efficiency due to its simple sealing structure and a long duration of operating period with single filling. However, its disadvantage is larger flow resistance than oil lubrication in light of efficiency to large cooling capability and high speed application.

Oil lubrication has advantage in large cooling capability and high speed application due to its good flow characteristics. However, it demands design with consideration to sealing structure and leakage prevention. The Table-31 compares the two lubrication methods as a guidance for lubrication method selection.

Table-31 Comparison of grease and oil lubrication

Lubrication method	Grease	Oil
Replacement of lubricant	△	○
Lubrication performance	○	◎
Cooling efficiency	×	○
Sealing structure	○	△
Power loss	△	○
Maintenance	○	△
High speed operation	×	○

Table-30 Value of tolerance class IT for reference dimension

Unit: μm

Reference dimension mm		Tolerance class					
Over	Incl.	IT2	IT3	IT4	IT5	IT6	IT7
3	6	1.5	2.5	4	5	8	12
6	10	1.5	2.5	4	6	9	15
10	18	2	3	5	8	11	18
18	30	2.5	4	6	9	13	21
30	50	2.5	4	7	11	16	25
50	80	3	5	8	13	19	30
80	120	4	6	10	15	22	35
120	180	5	8	12	18	25	40
180	250	7	10	14	20	29	46
250	315	8	12	16	23	32	52

## 7-3 Grease lubrication

### Filling amount of grease

Grease shall be packed up to volume approximately one-third to one-half of internal space of bearing or housing. Excessive grease may cause degraded lubrication performance due to leakage of softened grease or oxidation as a result of increased temperature inside of bearing. This should be critical especially in high speed operation.

Figure-9 shows an example of grease replenishment plan from side way using a ring with grease hole. Arranging grease holes evenly on circumference of the ring allows simultaneous entry of replenished grease into bearing for replacing old grease with new one. However, this design also allows standing old grease in opposite side space, which needs to be removed periodically by removing the cover.

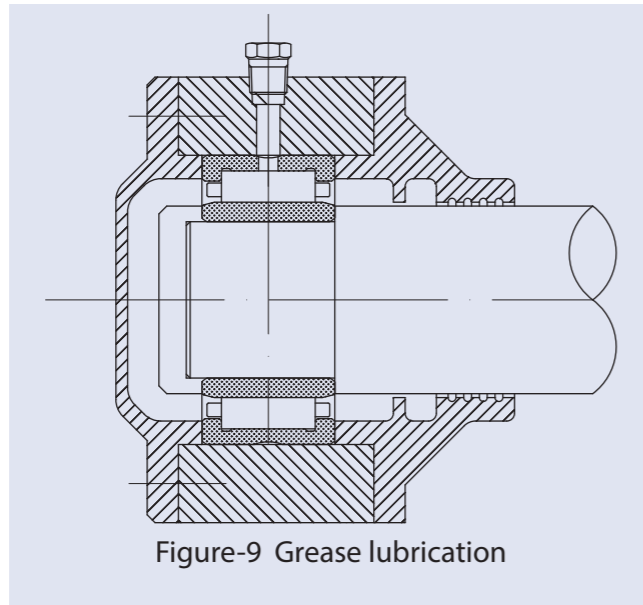

Figure-9 Grease lubrication

### Lubrication grease

Grease is a semi-solid lubricant consisting of a base oil (liquid lubrication agent) and a thickener, which are combined on heating.

Table-32 Type and properties of grease (reference)

Name	Lithium grease			Sodium grease	Calcium base grease	Aluminum grease	Non-soap grease	
Thickener	Li soap			Na soap	Ca + Na soap Ca + Li soap	Al soap	Bentonite, urea, etc	
Base oil	Mineral oil	Diester oil	Silicon oil	Mineral oil	Mineral oil	Mineral oil	Mineral oil	Synthetic oil
Dropping point °C	170~190	170~190	200~250	150~180	150~180	70~90	250 or more	250 or more
Working temperature °C	-25~+120	-50~+120	-50~+160	-20~+120	-20~+120	-10~+80	-10~+130	-50~+200
Mechanical stability	Good	Fair	Fair	Good~Fair	Good~Fair	Fair~Poor	Fair	Fair
Pressure resistance	Fair	Fair	Poor	Fair	Good~Fair	Fair	Fair	Fair
Water resistance	Fair	Fair	Fair	Fair~Poor	Fair~Poor	Fair	Fair	Fair
Application	Most various Versatile rolling bearing grease	Superior in low temperature, friction properties	Suitable for high and low temperature Unsuitable for high load due to low oil film strength	Subject to emulsifying by mixing with water Relatively good properties to high temperature	Superior in water resistance and mechanical stability Suitable for bearing being subjected to vibration	Superior in viscosity Suitable for bearing being subjected to vibration	Vast application from low to high temperature. It includes types showing superior properties in resistance to high and low temperature, and to chemical by combination with base oil and thickener Versatile rolling bearing grease	

Remark Working temperature range is for general properties only and NOT for guarantee purpose.

#### 1) Base oil

Mineral oil and mixed oil are used for base oil of grease.

Diester oil and silicone oil are used as mixed oil.

Lubrication performance depends on viscosity of the base oil, and generally, low viscosity base oil is suitable for low temperature environment and high speed application, and high viscosity is for high temperature and high load application.

#### 2) Thickener

Thickener is a material to keep grease in semi-solid state. Type of thickener has impact to maximum working temperature, water resistance and mechanical stability.

Metal-soap base is popular for material of thickener. In addition, there are thickeners such as urea base thickener with high heat resistance, and sodium soap-base thickener with poor water resistance due to easiness to emulsifying by mixing with water.



### 3) Consistency

Consistency refers to the “softness” of grease and it is used as a guideline for showing flow characteristics. The larger the ASTM penetration No. is, the softer the grease is. Table-33 shows typical relationship between consistency of grease and its operating conditions.

Table-33 Consistency of grease and its operating conditions

NLGI Grade No.	ASTM Penetration (1/10mm)	Operating conditions
0	355~385	Centralized lubrication Oscillating application
1	310~340	
2	265~295	General application
3	220~250	General, high temperature application
4	175~205	Grease with sealed application

### 4) Additives

Additives are material to improve performance of grease, which include antioxidants and extreme pressure additives added as necessary. Condition to use grease for long period without any replenishment requires added antioxidants to prevent oxidation.

Also, grease in operating conditions with heavy load or impact shock shall be selected from those with extreme pressure additives added.

### 5) Mixing different type greases

In principle, different brands of grease must not be mixed. Mixing different type grease is subject to negative impact each other due to change of consistency and difference of additives.

Table-34 Brand of lubricant grease (reference)

Category	Brand	Manufacturer	Thickener or soap-base	Consistency	Dropping point °C	Working temperature °C	Remark
General purpose	Alvania Grease S1	Showa Shell Sekiyu	Lithium soap	323	180	-35~120	General purpose
	Alvania Grease S2	Showa Shell Sekiyu	Lithium soap	283	181	-25~120	General purpose
	Alvania Grease S3	Showa Shell Sekiyu	Lithium soap	242	182	-20~135	General purpose
Wide working temperature	Fomblin RT-15	Solvay Solexis	PTFE	NO.2	300 or more	-20~250	High temperature
	Fomblin Y-VAC1	Solvay Solexis	PTFE	NO.1	300 or more	-20~250	High vacuum (soft)
	Fomblin Y-VAC2	Solvay Solexis	PTFE	NO.2	300 or more	-20~250	High vacuum (normal)
	Fomblin Y-VAC3	Solvay Solexis	PTFE	NO.3	300 or more	-20~250	High vacuum (rigid)
Low temperature	Multemp PS No.2	KYODO YUSHI	Lithium soap	NO.2	190	-50~130	Low temperature
Other	LOR#101	OIL CENTER RESEARCH	PTFE	295	198	-40~188	Superior in abrasion resistance, load resistance, water resistance and chemical resistance
	HP300	Dow Corning	PTFE	280	-	-65~250	Load resistance, oil resistance, solvent resistance, chemical resistance
	BARRIERTA SUPER IS/V	NOK KLUBER	PTFE	No.2	-	-35~260	High vacuum
	BARRIERT IEL/V	NOK KLUBER	PTFE	No.2	-	-65~200	High vacuum
	ISO FLEX TOPAS NB 52	NOK KLUBER	Barium soap	No.2	240 or more	-50~150	Superior in heat resistance, load resistance, water resistance and high speed
	DEMNUM L-200	DAIKIN	PTFE	280	-	-60~300	High temperature stability
	DEMNUM L-65	DAIKIN	PTFE	280	-	-70~200	High temperature stability
	G1/3Grease	The Orelube Corporation	Non-soap grease	No.2	-	-23~180	High temperature, high load
	Shell Cassida Grease RLS2	Showa Shell Sekiyu	Aluminium complex	No.2	240 or more	-30~120	Superior in water resistance, oxidation stability and mechanical stability
	Super Lube item number 82329	Henkel	PTFE	No.2	-	-42~232	Extreme pressure, high temperature
Castrol Microcote 296	Castrol	PTFE	No.2	256	-50~204	Heat stability, low volatility, shear stability, high vacuum	

## 7-4 Oil lubrication

Oil lubrication is more suitable than grease for high speed rotation with superior cooling efficiency. It is suitable for application that requests emission of heat to outside that are generated in bearing or added to the bearing.

### 1) Oil bath lubrication

Oil bath lubrication is the most popular method used in medium to low speeds. Amount of oil needs to be properly controlled with oil gauge. Most proper oil amount may be with oil level at the center of the lowest needle roller of bearing. Housing design with less variation of oil level is preferable.

### 2) Oil drop lubrication

Oil drop lubrication is broadly used in application with high speed and medium load due to its better cooling efficiency than oil bath lubrication. Oil dripping through oiler in this method removes friction heat in a method to lubricate with oil fog filling inside of housing by hitting rotating objects such as shafts and nuts. While amount of oil varies depending on type of bearing and speed, general amount should be a couple of drops per minute.

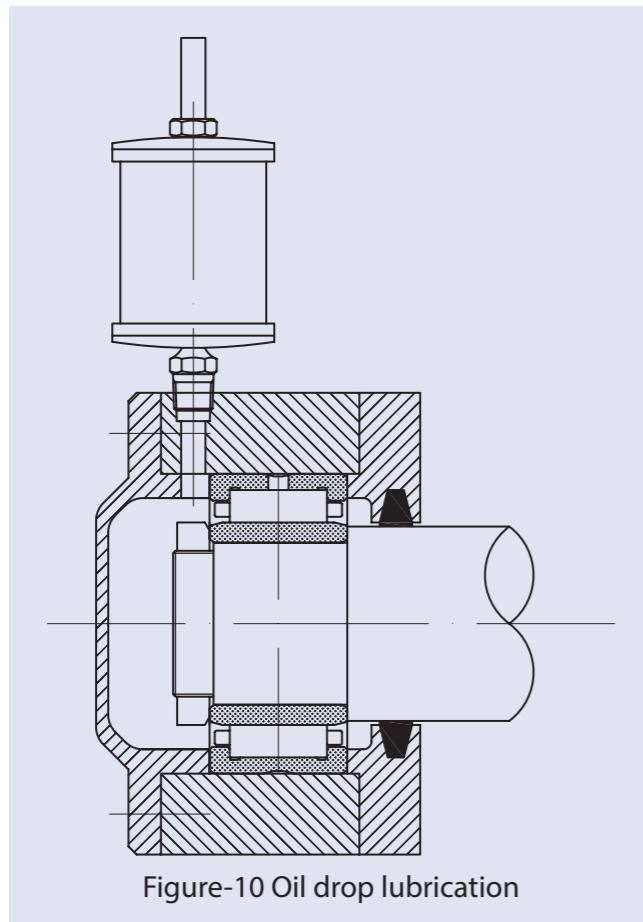

Figure-10 Oil drop lubrication

### 3) Oil splash lubrication

Oil splash lubrication is a method to splash oil with rotation of gear or disc. Unlike oil bath lubrication, it is applicable for relatively higher speed without having bearing in direct soak in oil.

### 4) Oil circulating lubrication

Oil circulating lubrication is widely used in application whose purpose is in cost efficiency for automatic lubrication with large number of lubrication spots, or is in cooling bearing. This lubrication method enables cooling or maintaining cleanness of lubricant with oil cooler and filters installed in oil circulation system. As shown in Figure-11, to make sure that lubrication oil is drained off certainly, it is important to have as much large outlet port as practical or forced outlet, setting inlet and outlet port of lubrication oil to opposite side each other to bearing.

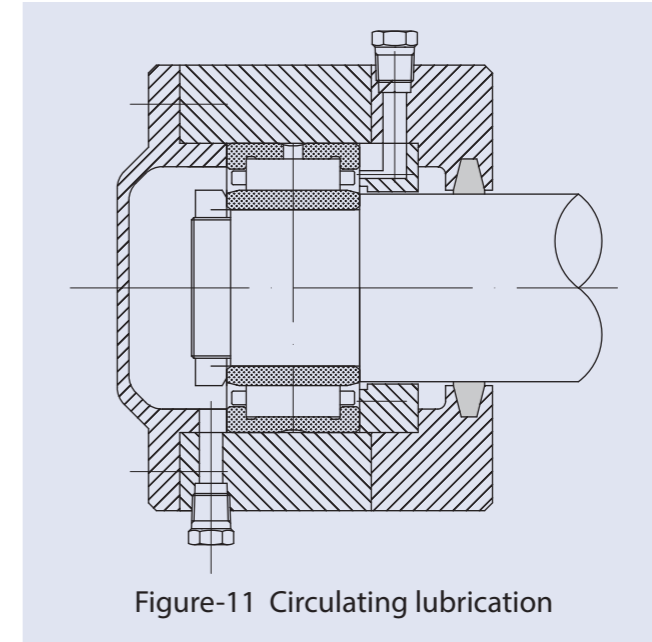

Figure-11 Circulating lubrication

### Lubrication oil

Highly refined mineral oil such as spindle oil, machine oil or turbine oil, or mixed oil are used as lubrication oil for bearing. Additives such as antioxidants, extreme pressure additives or deparant are selectively used as necessary in accordance with application.

It is important to select oil with proper viscosity for operation temperature. Too low viscosity causes insufficient formation of oil film which results in abrasion or heat-seizure. Too high viscosity causes heat generation or loss of power due to viscosity resistance. In general, oil with higher viscosity is used for higher load and lower viscosity for higher speeds.

## 8 Bearing handling

### 8-1 Precaution

Bearings are an extremely precision mechanical components. Exercise great care for its handling. Followings are precautions for the handling.

#### 1) Keep bearings and surroundings clean

Foreign matters invaded inside of bearings such as dust and dirt have harmful effect in rotation or operation life on the bearings. Take extra precaution to maintain cleanness of bearing, surrounding components, work tools, lubricants, lubrications oil and working environment.

#### 2) Handle bearings carefully

Shocks such as caused by falling bearing may result in damage or impressions on track or rolling elements. They can be a cause of failure so that handle bearings carefully.

#### 3) Use proper tools

Make it sure to use work tools properly for bearing type for assembling and disassembling.

#### 4) Pay attention to rust

Although bearings are applied with anti-rust oil, handling with bare hands may cause generation of rust with perspiration from hands. Exercise care and use rubber gloves or apply mineral oil to hands when handling with bare hands.

### 8-2 Mounting

#### Preparation

Bearings should be mounted in clean and dry circumstance. Dirt on mounting tools should be removed prior to mounting work, then verify that dimension accuracy, shaft and housing roughness and geometric accuracy are within designed tolerance.

Packing of bearings should be opened just before start mounting. Fill lubrication grease without washing bearing in the case of grease lubrication. Washing is generally not required for oil lubrication as well. Still it is recommended to thoroughly wash out oil and grease when application demands high accuracy or lubricating performance is degraded by mixing lubricant and anti-rust agents.

#### Mounting method

##### 1) Press fitting

In mounting bearings from small to medium sizes which don't need large forces, press fittings in room temperature are conducted widely. In this case, use pressing fixture as shown in Figure-12 to apply force evenly at side of bearing and press it in carefully. Applying high viscosity oil on fitting surface during work may reduce friction on the surface.

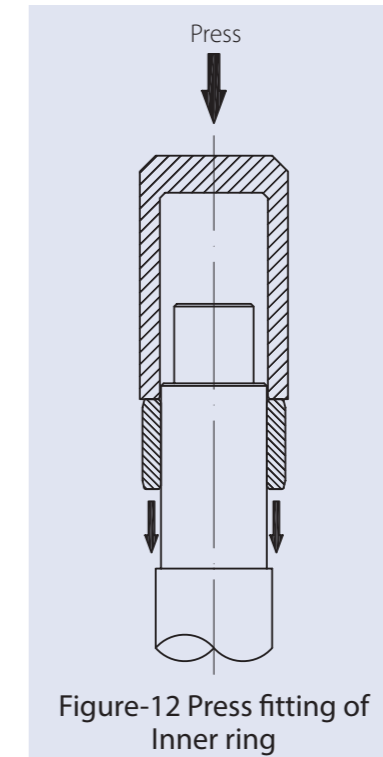

##### 2) Shrink fitting

Shrink fitting is broadly used for tighter interference or mounting large size bearing. How to fit is heating housing for outer ring and inner ring for shaft respectively with pure mineral oil with less corrosivity in order to expand their inner diameter for mounting onto the shaft. Heating temperature must not exceed 120° C. During mounting, inner ring could expand toward shaft direction so that it needs to be pressed against shoulder until completion of cool down to avoid gap between the inner ring and the shoulder.

### 8-3 Operation inspection

Operation inspection needs to be performed in order to confirm that bearings is properly mounted. Power operation at given speed without operation inspection may result in damage of bearings or heat-seizure due to lubrication failure in the case that mounting is insufficient. Shaft or housing should be rotated by hand after bearing mounting to confirm if there is no abnormality followed by check (or inspection) in stepping increase of speed from no load, low speed operation with power up to loaded operation.

Followings are typical abnormal items and major causes that can be checked in the operation inspection.

#### 1) Check item in operation by hand

- Fluctuation in rotation torque, Insufficient mounting
- Sticks and abnormal noise, Impression, damage, invasion of dirt or foreign matters in track surface
- Excessive torque, Insufficiently small clearance

#### 2) Check item in operation by power

- Abnormal noise, vibration . . . . Impression, invasion of dirt or foreign matters in track surface, excessive clearance
- Abnormal temperature . . . . . Insufficient lubrication, insufficient mounting, insufficiently small clearance

### 8-4 Removing

Bearing may be removed for periodical machine maintenance or repair for trouble. Bearing and other components should be carefully disassembled in the same manner as the mounting in the case of re-using disassembled bearing or researching trouble condition.

Bearings should be carried out in an appropriate manner in accordance with type of bearing and condition of fits. Structure design should take disassembling work into consideration at planning stage of construction around the bearing since it would be difficult to disassemble especially the tight fit bearing.

#### Removing outer ring

Installing bolts for disassembling outer ring at several locations in circumference of housing will allow removing outer ring assembled with tight fits easily by tightening-up the screws evenly as shown in Figure-13.

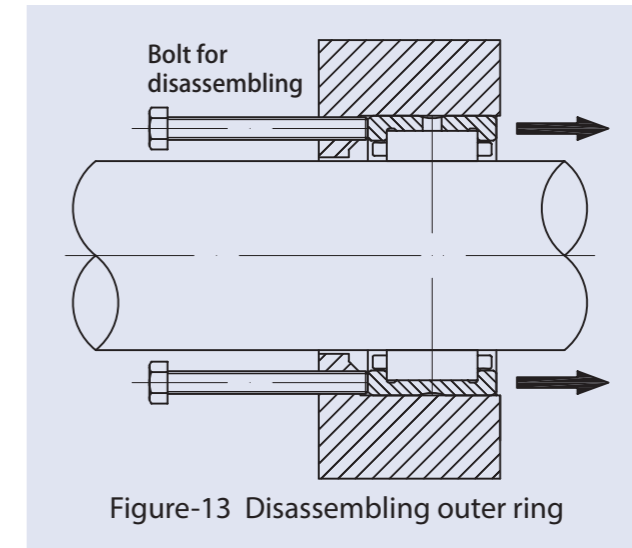









# MACHINED RING NEEDLE ROLLER BEARINGS





## Machined type needle roller bearings (NA, NK, NA..UU)

### Type and Part Code

Type	Applicable axis diameter	Feature	Part Code
 RNA48,49,59,69	$\phi 7 \sim \phi 175$	Machined type needle roller bearings With collar outer ring Without inner ring Without seal *Double rows: RNA69 ( $F_w \geq \phi 37$ )	<p><b>Type</b> <b>RNA</b> ↓ Type of bearing</p> <p><b>Dimensions</b> <b>49</b>   <b>10</b> ↓   ↓ Dimension series   Bore diameter number</p> <p><b>Suffix code</b> <b>P6</b> ↓ Classification symbol (Class 6) (Standard: No symbol, Class 0)</p>
 NK	$\phi 5 \sim \phi 110$	Machined type needle roller bearings Light load type With collar outer ring Without inner ring Without seal (There are no oil holes and oil grooves if the roller set bore diameter ( $F_w$ ) is 10 mm or less)	<p><b>Type</b> <b>NK</b> ↓ Type of bearing</p> <p><b>Dimensions</b> <b>40 / 20</b> ↓   ↓ Outer ring width   Inscribed circle diameter</p> <p><b>Suffix code</b> <b>P6</b> ↓ Classification symbol (Class 6) (Standard: No symbol, Class 0)</p>
 NA48,49,59,69	$\phi 5 \sim \phi 160$	Machined type needle roller bearings With collar outer ring With inner ring Without seal *Double rows: NA69 (shaft dia. $\geq \phi 32$ )	<p><b>Type</b> <b>NA</b> ↓ Type of bearing</p> <p><b>Dimensions</b> <b>49</b>   <b>10</b> ↓   ↓ Dimension series   Bore diameter number</p> <p><b>Suffix code</b> <b>C3</b>   <b>P6</b> ↓   ↓ Clearance symbol (C3 clearance) (Standard: No symbol, CN clearance)   Classification symbol (Class 6) (Standard: No symbol, Class 0)</p>
 NKI	$\phi 5 \sim \phi 100$	Machined type needle roller bearings Light load type With collar outer ring With inner ring Without seal (There are no oil holes and oil grooves if the bore diameter is 8mm or less)	<p><b>Type</b> <b>NKI</b> ↓ Type of bearing</p> <p><b>Dimensions</b> <b>35 / 20</b> ↓   ↓ Bore diameter   Outer ring width</p> <p><b>Suffix code</b> <b>C3</b>   <b>P6</b> ↓   ↓ Clearance symbol (C3 clearance) (Standard: No symbol, CN clearance)   Classification symbol (Class 6) (Standard: No symbol, Class 0)</p>
 RNA49,69..UU	$\phi 14 \sim \phi 58$	Machined type needle roller bearings With collar outer ring Without inner ring With seal *Double rows: RNA69 ( $F_w \geq \phi 42$ )	<p><b>Type</b> <b>RNA</b> ↓ Type of bearing</p> <p><b>Dimensions</b> <b>49</b>   <b>10</b> ↓   ↓ Dimension series   Bore diameter number</p> <p><b>Suffix code</b> <b>UU</b>   <b>P6</b> ↓   ↓ UU: With Seal   Classification symbol (Class 6) (Standard: No symbol, Class 0)</p>
 NA49,69..UU	$\phi 10 \sim \phi 50$	Machined type needle roller bearings With collar outer ring With inner ring With seal *Double rows: NA69 (shaft dia. $\geq \phi 35$ )	<p><b>Type</b> <b>NA</b> ↓ Type of bearing</p> <p><b>Dimensions</b> <b>49</b>   <b>10</b> ↓   ↓ Dimension series   Bore diameter number</p> <p><b>Suffix code</b> <b>UU</b>   <b>C3</b>   <b>P6</b> ↓   ↓   ↓ UU: With Seal   Clearance symbol (C3 clearance) (Standard: No symbol, CN clearance)   Classification symbol (Class 6) (Standard: No symbol, Class 0)</p>

## Structure and Features

Machined type needle roller bearings offer high stiffness and bearing accuracy and are of a structure whereby the cage and needle rollers are mounted on a machined outer ring. They can also be used in light metal housing due to the high stiffness of the outer ring.

Moreover, because the needle roller diameter is relatively small, the cross-sectional height is low, meaning that large radial loads can be supported in a small envelope. This enables machinery to be smaller and lighter.

There are machined type needle roller bearings both with and without inner rings, and the shaft can also be used directly as a track surface.

### Without inner ring

The shaft is directly used as the track surface of the machined type needle roller bearing. If using the shaft directly as a track surface, please refer to 6-2 Accuracy of track surface and 6-3 Material and heat treatment of track surface.

### With inner ring

If the shaft surface cannot achieve the specified hardness, accuracy and roughness, the type with an inner ring is used. The inner ring has been tempered and polished so it is of the hardness, accuracy and roughness required for the track and can be used as is.

### With seal

NA49UU and NA69UU have seals embedded in both ends. The synthetic rubber seals help to prevent lubricant leakage and the infiltration of external dust.

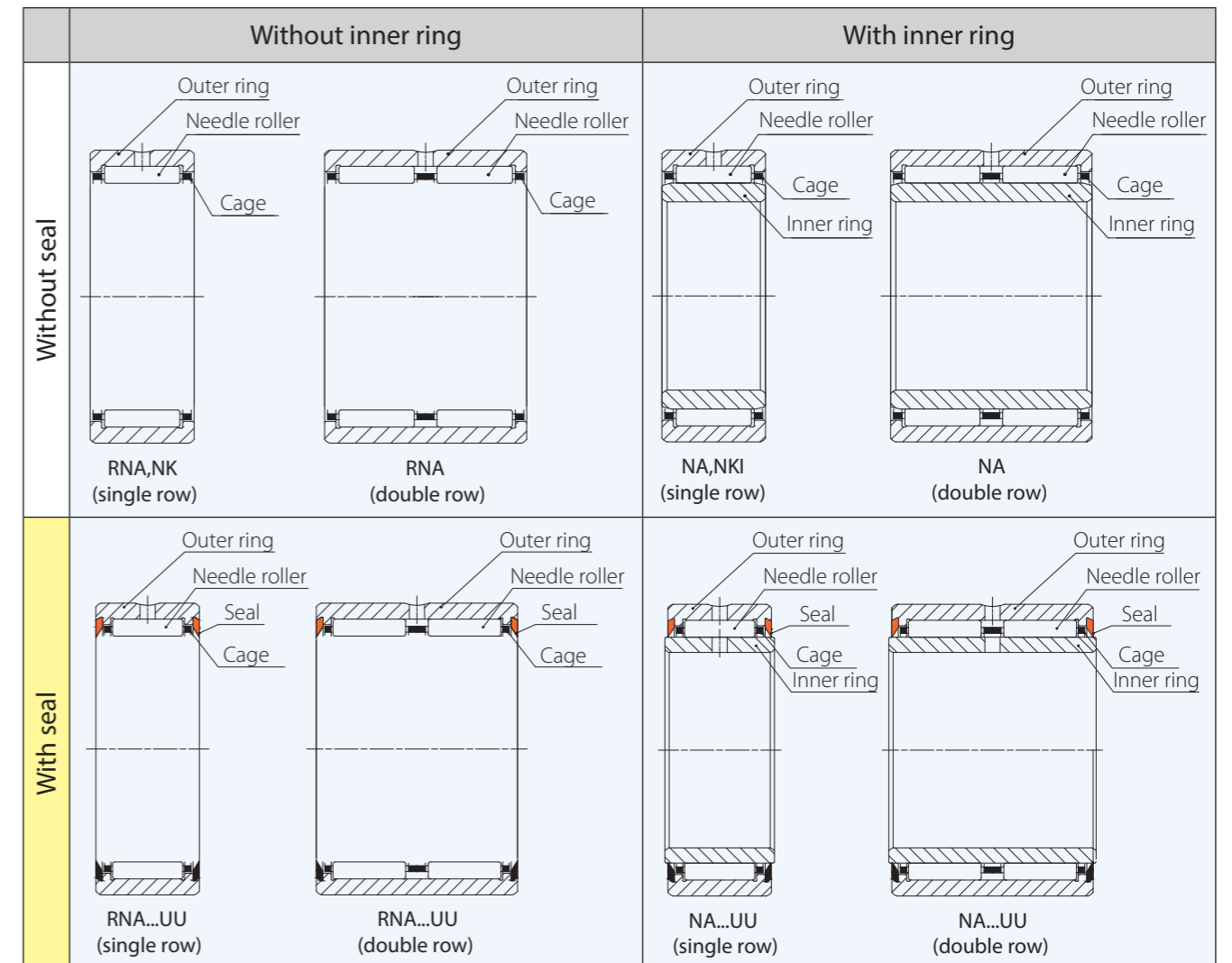



# SEPARABLE NEEDLE ROLLER BEARINGS



## Machined type needle roller bearings - Separable type (NAF)

### Type and Part Code

Type	Applicable axis diameter	Feature	Part Code
 RNAF(W)	$\phi 5 \sim \phi 100$	Machined type needle roller bearings Without collar outer ring Without inner ring	<p><b>Type</b> RNAF ↓ Type of bearing</p> <p><b>W</b> ↓ No symbol: Single row W: Double row</p> <p><b>Dimensions</b>                      30 ↓ Inscribed circle diameter                      42 ↓ Outer diameter                      32 ↓ Width</p> <p><b>Suffix code</b> P6 ↓ Classification symbol (Class 6) (Standard class 0 No symbol)</p>
 NAF(W)	$\phi 6 \sim \phi 90$	Machined type needle roller bearings Without collar outer ring With inner ring	<p><b>Type</b> NAF ↓ Type of bearing</p> <p><b>W</b> ↓ No symbol: Single row W: Double row</p> <p><b>Dimensions</b>                      25 ↓ Bore diameter                      42 ↓ Outer diameter                      32 ↓ Width</p> <p><b>Suffix code</b>                      C3 ↓ Clearance symbol (C3 clearance)                      (Standard: No symbol, CN clearance)                      P6 ↓ Classification symbol (Class 6)                      (Standard class 0 No symbol)</p>

These are semi-standard products, so please direct any enquiries to JNS.

### Structure and Features

A metric bearing which features a stiff machined outer ring and a cage with either a single or a double row of needle rollers. This bearing has no collar on the inside of the outer ring therefore the cage with needle rollers can be easily separated from the outer and inner rings.

Because these bearing can be individually mounted on equipment, assembly is sometimes easier. The cage with needle rollers is not constrained by a collar therefore the configuration must be one which constrains the movement of these parts.

Also, this type of bearing is not available with a seal.

On the single row standard type, there are no oil grooves and oil holes for lubrication on the outer ring, and no oil holes on the inner ring.

On the double row standard type, there are oil grooves and oil holes for lubrication on the outer ring, but no oil holes on the inner ring.

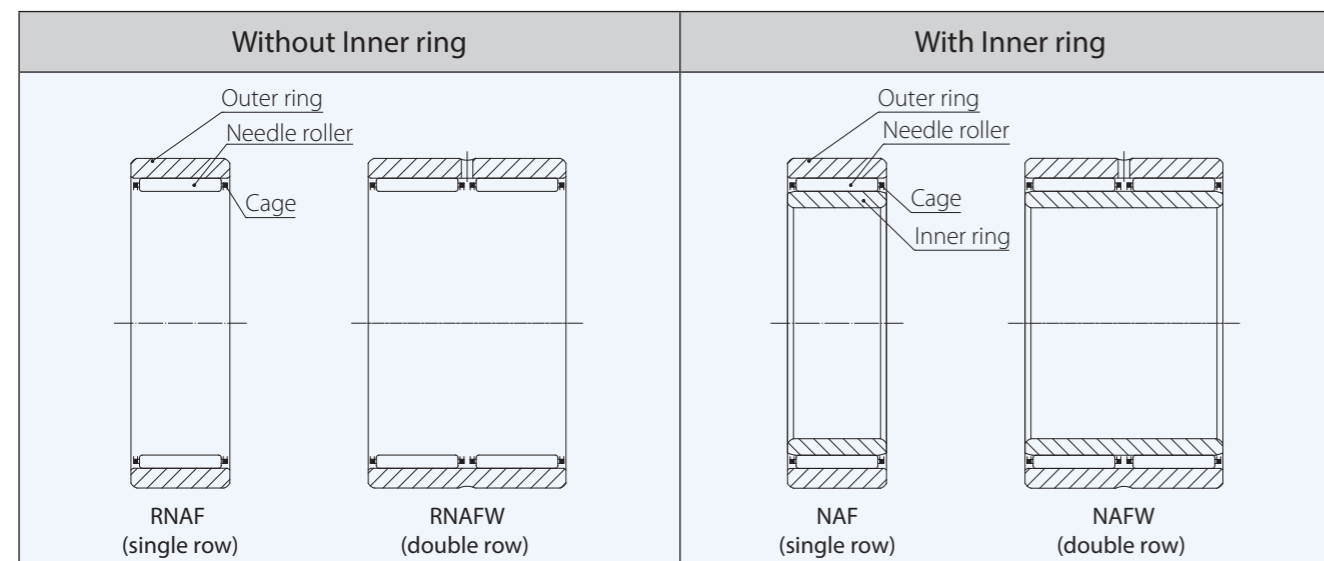





# COMBINED NEEDLE ROLLER BEARINGS





## Combined needle roller bearings (NKX..(Z), NKXI..(Z))

### Type and Part Code

Type	Applicable axis diameter	Feature	Part Code
 NKX..(Z)	φ 10 ~ φ 70	Machined type combined bearing Radial bearing: needle bearing Thrust bearing: ball bearing With collar outer ring Without inner ring	<b>Type NKX</b> ↓ Type of bearing  <b>Dimensions 30</b> ↓ Inscribed circle diameter  <b>Z</b> ↓ Z: With dust cover No symbol: Without dust cover
 NKXI..(Z)	φ 7 ~ φ 60	Machined type combined bearing Radial bearing: needle bearing Thrust bearing: ball bearing With collar outer ring With inner ring	<b>Type NKXI</b> ↓ Type of bearing  <b>Dimensions 25</b> ↓ Bore diameter  <b>Z</b> ↓ Z: With dust cover No symbol: Without dust cover  <b>Suffix code C3</b> ↓ Clearance symbol (C3 clearance) (Standard: No symbol, CN clearance)

### Structure and Features

Combined needle roller bearings are made from a combination of radial needle bearings which support radial load and thrust ball bearings which support axial load.

Combined needle roller bearings are compact and simultaneously supports both radial and axial load. As such, it is possible to design more compact equipment as the space occupied by bearings can be kept small.

Moreover, on the type featuring a dust cover, the thrust bearing does not separate, therefore it is easy to handle and when greasing, splattering caused by centrifugal force within the thrust bearing can be prevented.

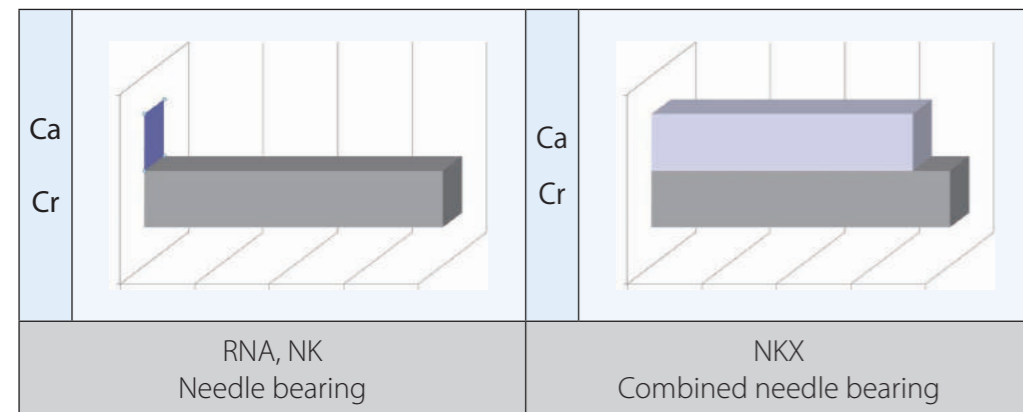

Ca : Axial load  
Cr : Radial load

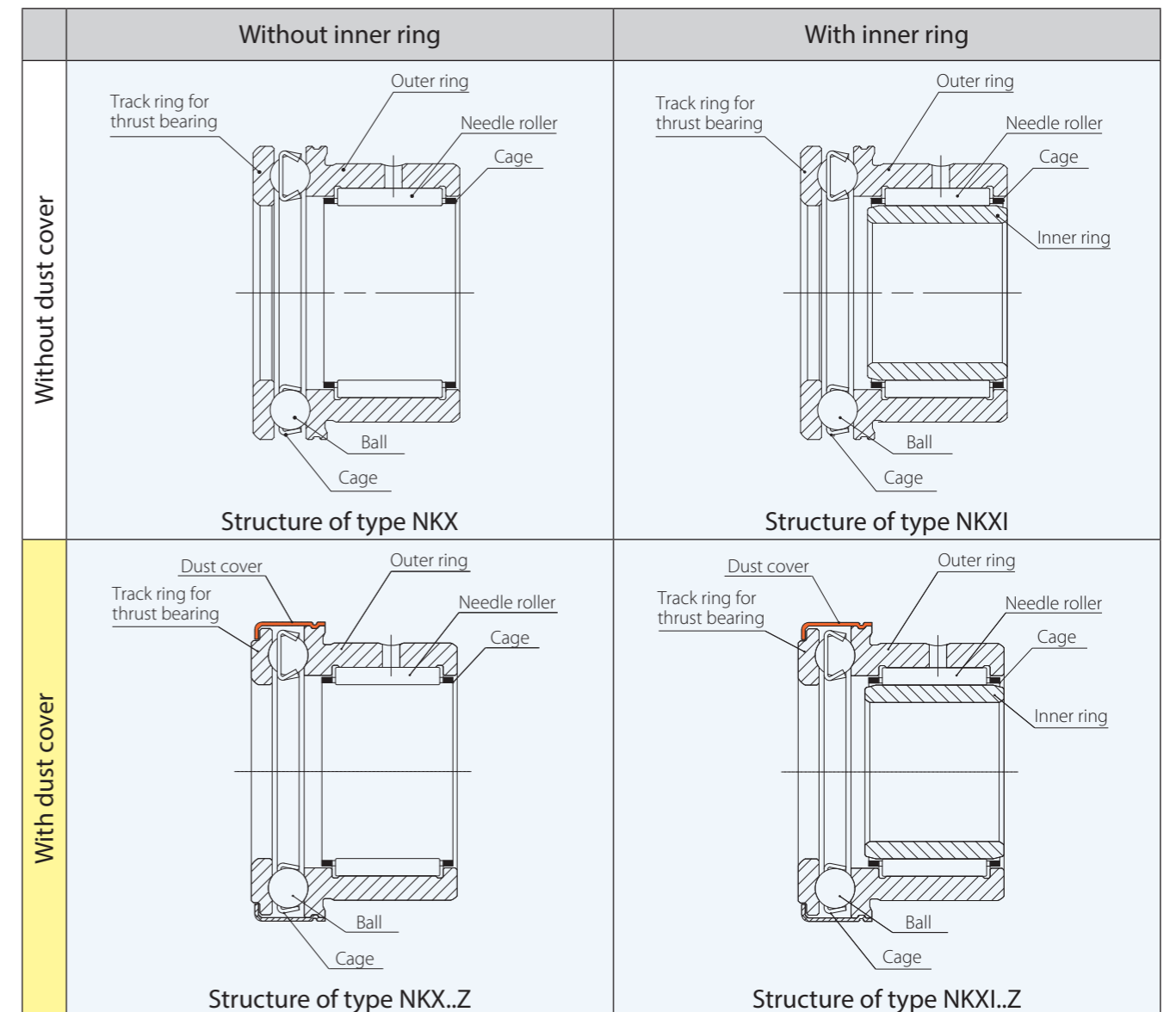

## Accuracy standard

Please refer to page 22 regarding accuracies for the radial section of combined needle bearings. Table-1 indicates thrust section accuracies.

Table-1 Thrust section accuracies

Unit:  $\mu\text{m}$

Part code	Inner ring		Outer ring			Inner ring/Outer ring			
	$\Delta_{\text{dmp}}$ Deviation of mean bore diameter in a single plane	$V_{\text{dsp}}$ Variation of bore diameter in a single plane	$\Delta_{\text{Dmp}}$ Deviation of mean outer diameter in a single plane	$V_{\text{Dsp}}$ Variation of outer diameter in a single plane	$S_i/S_e$ Variation of track thickness				
					Class 0	Class 6	Class 5		
	high	low	max.	high	low	max.	max.		
NKX10 to 15(Z) NKXI7 to 12(Z)	0	-8	6	0	-11	8	10	5	3
NKX17 to 30(Z) NKXI14 to 25(Z)	0	-10	8	0	-13	10	10	5	3
NKX35 to 50(Z) NKXI30 to 45(Z)	0	-12	9	0	-16	12	10	6	3
NKX60 to 70(Z) NKXI50 to 60(Z)	0	-15	11	0	-19	14	10	7	4

Table-2 indicates the accuracies of the assembled bearings.

Table-2 Assembled bearing accuracy

Unit: mm

d	D	C	C1
E8 (Fitting accuracy)	H5 (Fitting accuracy)	MAX. 0 MIN. -0.25	MAX. 0 MIN. -0.2

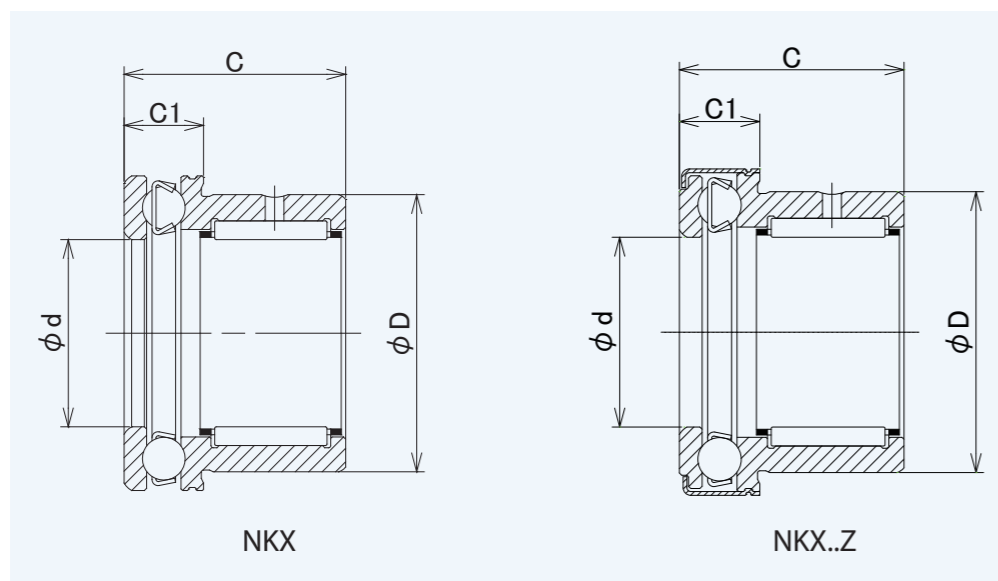

## Radial internal clearance

Table-3 indicates the radial internal clearances of combined needle bearings with inner rings (NKXI).

Table-3 Radial internal clearances Unit:  $\mu\text{m}$

Part code	Radial internal clearance	
	min.	max.
NKXI 7 to 25	20	45
NKXI 30 to 40	25	50
NKXI 45 to 50	30	60
NKXI 60	40	70
NKXI 70	40	75

## Fits

Table-4 indicates the recommended fits between the combined needle bearing and shaft and housing.

Table-4 Recommended fits Unit:  $\mu\text{m}$

Shaft tolerance		Housing tolerance
Without Inner ring	With Inner ring	
H5 K5	K5	K6, M6

## Lubrication

Please refer to page 43 - 7 Lubrication regarding lubrication for the radial and thrust sections of combined needle bearings. For both the time with a dust cover and without, grease is pre-packed into the thrust section before factory dispatch.

## Rating life

Please calculate rating life for radial needle bearings and thrust ball bearings respectively using the formula provided on page 12 - 1 Bearing Life and Load Rating. Assume that the radial needle bearing supports the radial element of load while the thrust ball bearing supports the thrust element. The overall rating life is then calculated using the respective calculation results in the below formula.

$$L = \left[ \left( \frac{1}{L_a} \right)^{3/2} + \left( \frac{1}{L_r} \right)^{3/2} \right]^{-2/3} \dots \dots \dots (0.0)$$

- $L$  : Basic rating life of combined needle bearings is  $10^6$  rotation  $10^6$  REV.
- $L_r$  : Basic rating life of radial needle bearings is  $10^6$  rotation  $10^6$  REV.
- $L_a$  : Basic rating life of thrust ball bearings is  $10^6$  rotation  $10^6$  REV.

## Mounting

The below is an example of combined needle bearing mounting. The thrust section housing and its clearance must be made 0.5 mm or greater than the outer diameter of the outer ring collar (NKX(I)) and the outer diameter of the dust cover (NKX(I)..Z).

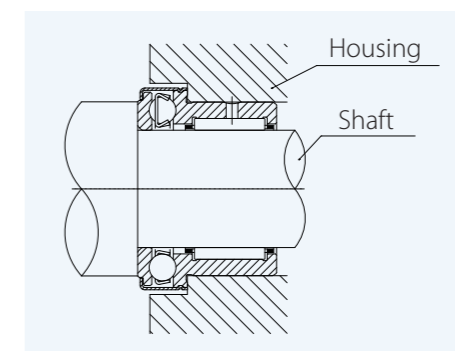



# INNER RINGS



## Inner ring (IR, IRZ)

### Type and Part Code

Type	Applicable axis diameter	Feature	Part Code
 IR	$\phi 5 \sim \phi 160$	Inner ring (without oil hole)	<div style="display: flex; justify-content: space-around; align-items: flex-start;"> <div style="text-align: center;"> <p><b>Type</b> <b>IR</b></p> <p>↓</p> <p>Type of bearing</p> </div> <div style="text-align: center;"> <p><b>Dimensions</b></p> <p><b>25</b></p> <p>↓</p> <p>Bore diameter</p> </div> <div style="text-align: center;"> <p><b>30</b></p> <p>↓</p> <p>Outer diameter</p> </div> <div style="text-align: center;"> <p><b>17</b></p> <p>↓</p> <p>Width</p> </div> </div>
 IRZ	$\phi 10 \sim \phi 50$	Inner ring (with oil hole)	<div style="display: flex; justify-content: space-around; align-items: flex-start;"> <div style="text-align: center;"> <p><b>Type</b> <b>IRZ</b></p> <p>↓</p> <p>Type of bearing</p> </div> <div style="text-align: center;"> <p><b>Dimensions</b></p> <p><b>25</b></p> <p>↓</p> <p>Bore diameter</p> </div> <div style="text-align: center;"> <p><b>30</b></p> <p>↓</p> <p>Outer diameter</p> </div> <div style="text-align: center;"> <p><b>18</b></p> <p>↓</p> <p>Width</p> </div> </div>

### Structure and Features

For needle bearings, normally a shaft is subjected to heat treatment and is given a grinding finish before being used as a track surface, however, if the specified hardness and roughness cannot be achieved, inner rings are used.

Inner rings, after being subjected to heat treatment, are given a high accuracy grinding finish. The endfaces are chamfered to allow easy insertion into the bearing and to prevent damage to the seal. Depending on the conditions of use, there are inner rings with oil holes or without oil holes available to select from.

It is preferable to use wide inner rings in cases where there is large shaft travel in the axial direction or a seal is used on the outside of the bearing.

Inner rings can also be used as bushes.

