





ROLLER FOLLOWERS



Type and Part Code

Type	Applicable shaft diameter	Feature	Part Code
 <p>RNAS T (Separable type)</p>	φ 7 ~ φ 60	NAS T type without inner ring.	<p>RNAS T 15 R</p> <p>↑ ↑ ↑</p> <p>Type Bore diameter code R: Crowned outer ring None: Cylindrical outer ring</p>
 <p>NAS T (Separable type)</p>	φ 6 ~ φ 50	Thick wall outer ring, inner ring. Separable bearing with combined needle roller with precision cage.	<p>NAS T 15 R</p> <p>↑ ↑ ↑</p> <p>Type Bore diameter code R: Crowned outer ring None: Cylindrical outer ring</p>
 <p>NAS T-ZZ (Separable type)</p>	φ 6 ~ φ 50	Separable bearing in which labyrinth seal is formed with combined side plate at both sides of inner ring of NAS T type. (NAS T-ZZUU type comes with seal)	<p>NAS T 15 ZZ UU R</p> <p>↑ ↑ ↑ ↑ ↑</p> <p>Type Bore diameter code ZZ: With shield UU: With seal R: Crowned outer ring X: Cylindrical outer ring None: With shield</p>
 <p>NART-R (Non-separable type)</p>	φ 5 ~ φ 50	Non-separable bearing with fixed side plate at inner ring. Mitigate eccentric load with spherical shape at outer diameter of outer ring (code R). (NART-UUR type comes with seal)	<p>NART 15 UU V R</p> <p>↑ ↑ ↑ ↑ ↑</p> <p>Type Bore diameter code UU: With seal V: Full complement R: Crowned outer ring None: With shield X: Cylindrical outer ring None: With cage</p>

Structure and Features

Roller follower is a bearing with integrated "roller" featuring high rigidity. Its primary application is in a guide roller to have its contacting member travel in linear motion in direction of tangent using rotation of outer ring.

Outer ring of the roller follower is designed with thick ring in order to provide high rigidity to endure heavy load or impact load at portion to contact with the associated objects.

Type of roller follower mainly consists of separate type, which have separated inner ring and outer ring, and non-separate type, whose inner ring has fixed side plate.

Also, various types with shapes and structures are available in accordance with application. Outer rings have two types – crowned outer ring and cylindrical outer ring. The crowned outer ring is suited for absorbing eccentric load since it absorbs angular misalignment due to a mount error. Cylindrical outer ring is effective for heavy duty since it contacts with large contact area of the associated objects so that can mitigate the contact surface pressure. They have two internal mechanism – one with cage and one with full complement. A roller follower with cage is suitable for high speed application since the guiding feature of cage enables the rotation of "rollers" to be stable. Compared with cage type, full complement type is effective for applications with low-speed operation of heavy load due to its larger load rating. Full complement type also includes double-row cylindrical roller type which allows moderate axial loading.

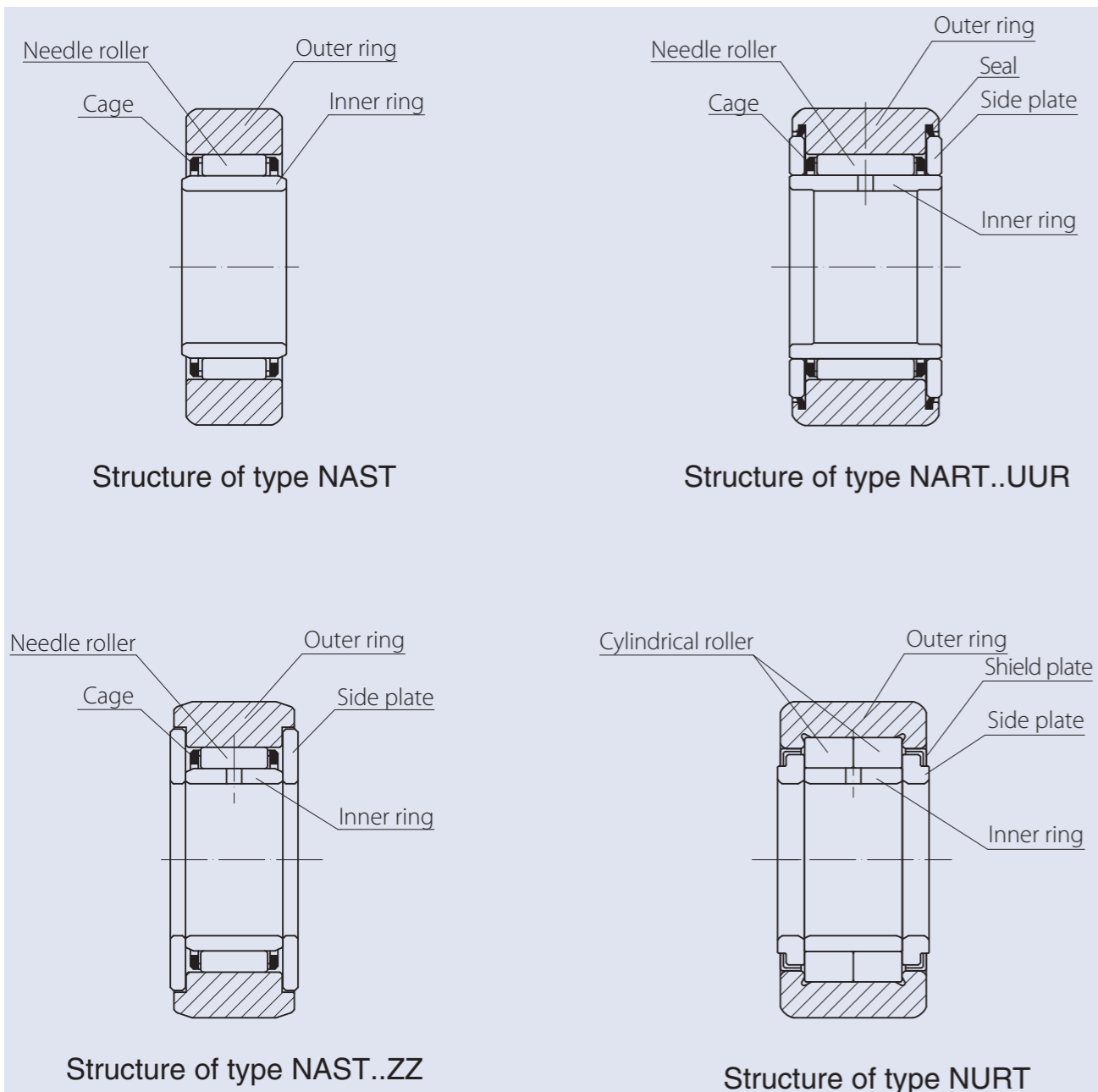

Accuracy standard

Roller followers are manufactured in accordance with the following accuracies.

Unit: μm

Name	Category	Crowned outer ring	Cylindrical outer ring
Dimension tolerance of outer ring outer diameter (D)		0 -50	Refer to Table-3
Dimension tolerance of outer ring width (C)		0 -120	
Tolerance of inner ring width (B)	Separable	0 -120	
Tolerance of bearing width (B)	Non-separable	h12	—
Fw	Separable	Refer to Table-11 on page 23	

Unit: μm

Nominal inner ring bore diameter d (mm)		Deviation of mean bore diameter in a single plane Δ_{dmp}		Tolerance of radial runout of inner ring
Over	Incl.	high	low	max.
2.5	10	0	-8	10
10	18	0	-8	10
18	30	0	-10	13
30	50	0	-12	15

Unit: μm

Nominal outer ring bore diameter D (mm)		Deviation of mean outer diameter in a single plane Δ_{Dmp}		Tolerance of radial runout of outer ring (max.)
Over	Incl.	high	low	max.
6	18	0	-8	15
18	30	0	-9	15
30	50	0	-11	20
50	80	0	-13	25
80	120	0	-15	35

Radial internal clearance

Table below indicates radial internal clearance of roller follower.

Table-4 Radial internal clearance

Unit: μm

Part code			Radial internal clearance	
Separable	Non-separable	Double row cylindrical roller	min.	max.
NAST6	NART5R ~ 6R	—	5	20
NAST8 ~ 12	NART8R ~ 12R	—	5	25
NAST15 ~ 25	NART15R ~ 25R	—	10	30
NAST30 ~ 40	NART30R ~ 40R	—	10	40
NAST45 ~ 50	NART45R ~ 50R	—	15	50
—	—	NURT15R ~ 30-1R	0	25
—	—	NURT35R ~ 40-1R	5	30
—	—	NURT45R ~ 50-1R	5	35

Fits

Table below indicates recommended fits between roller follower and its mounting shaft.

Table-5 Shaft fits

Type		Tolerance grade
Separable	Without inner ring	k5,k6
	With inner ring	g6,h6
Non-separable		
Double row cylindrical roller		

Track load capacity

Track load capacity means a permissible load under which the outer ring of cam follower and the mating surface are allowable to be used over a long period without causing any deformation nor compression mark. Track load capacity depicted in dimension table indicates a value for which hardness of contacting steel member is assumed to be HRC40. In the case that the hardness of contacting member is not HRC40, track load capacity in the dimension table shall be multiplied by value of track capacity factor obtained by Figure-1.

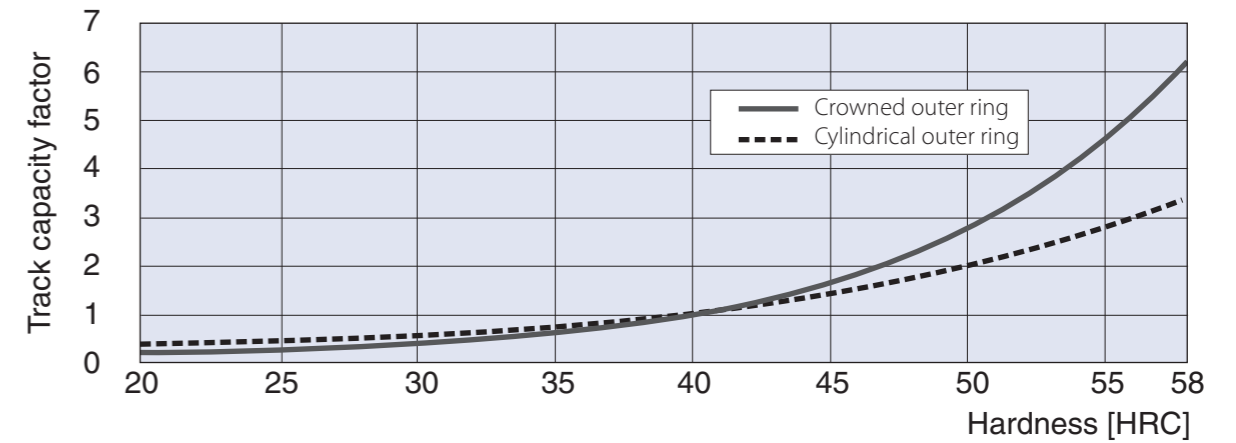

Figure-1 Track capacity factor

Lubrication

All the JNS roller followers are lubricated with pre-packed high quality lithium soap-based grease grade 2 (RoHS compliant) so that they are ready to use. For applications requiring high prevention measure against invasion of foreign matter or leakage of lubricant, products with seal (part code--UU) which integrate special synthetic lubber with high abrasion resistance are also available.

Grease shall be packed up to volume approximately one-third to one-half of internal space of bearing. Lubrication interval varies depending on operation condition. Referential interval may be every six to twenty four months for roller followers with cages and every one to six months for full complement type with grease in the same type.

Some excessive grease may leak at the beginning of usage or immediately after re-greasing even for the products with seal. Aging operation period is recommended prior to application in which no contamination by grease is allowed in and around device. Wipe and clean any leaked extra grease after this operation.

Mounting

Mounting part

- Thrust load may cause damage to side plate, outer ring or roller follower since it is designed so as to support load in radial direction. It is recommended to design and assemble to avoid thrust load.
- Application with roller follower without inner ring requires heat treatment and grinding finish of shaft. Surface hardness of the shaft shall be HRC58 to 64, and surface roughness shall be R_a 0.2 μ m or less for this application.
- Side plate of non-separate type roller follower is pressed-in to fix it. Application in a manner to push the side plate shall be avoided in order to prevent risk of abnormal rotation under external force.
- Crowned outer ring is recommended in the case that contact between the outer ring and contacting member track surface is not smooth and even.
- When mounting NART, NAST-ZZ and NURT type, dimension "a" must be more than it described in dimension table in order to protect the side plate.

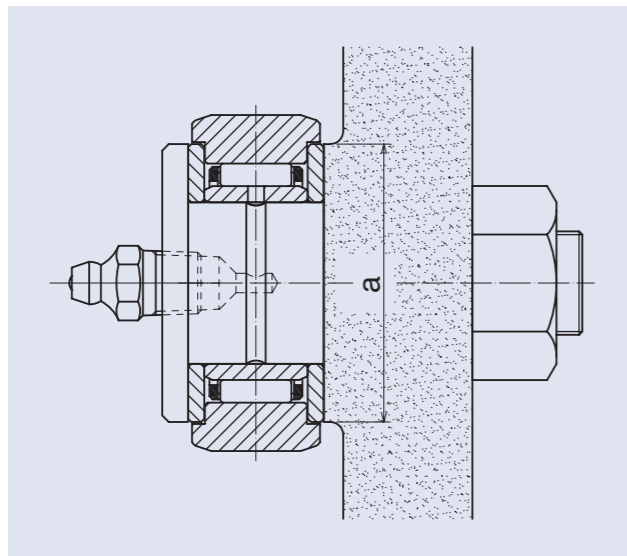

Mounting method

To prevent pre-mature failure of roller follower, lubrication hole of inner ring shall be located outside of loading range (on the side to receive load).

