

CAM FOLLOWERS



Cam follower with pre-installed grease nipple

Newly available versatile cam follower which has conquered disadvantages in traditional products!!

CF..AB
Standard type

CF..MAB
Stainless type

CFH..AB
Eccentric type

CFH..MAB
Eccentric stainless type

Ready use instantly after unpack the box thanks to pre-installed grease nipple.

•Conventional type: Need to fit a nipple

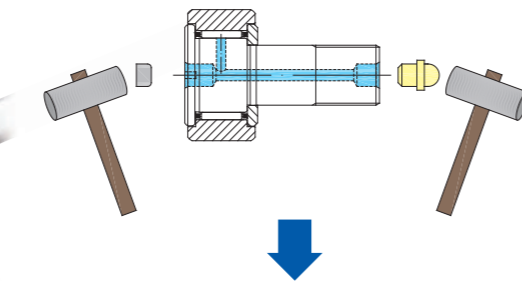

•Grease nipple fitted

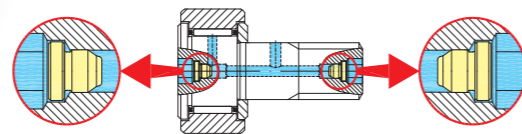

Lubrication available from both stud head side and thread side. No restriction for mounting location.

NUCF..AB

Double-row cylindrical roller type

stud diameter
16 to 30mm

•Need to machine an internal oil groove

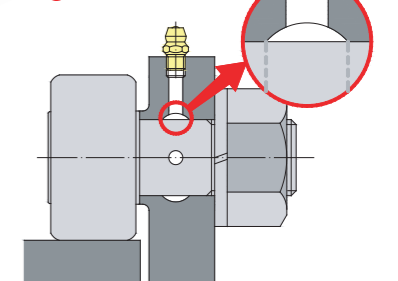

•Lubrication enabled only by vertical hole

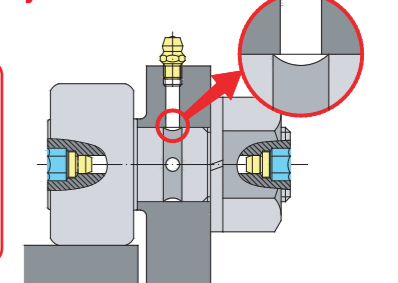

Lubrication area at the side of stud has an oil groove to eliminate bothersome groove machining process in the mounting side(NUCF type).

No restriction for mounting location thanks to hexagon socket shape in stud head and thread side. Easy mounting and removal is available thanks to having hexagon socket shape in both side.

Conventional type (CF..B):
Mountable but cannot be lubricated

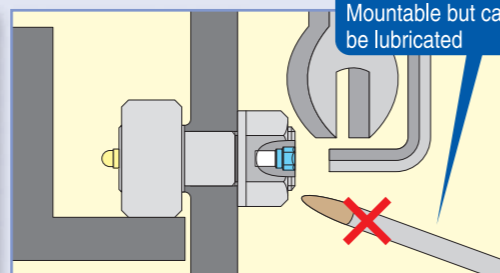

Mounting can be completed just by the screw side only in such a case

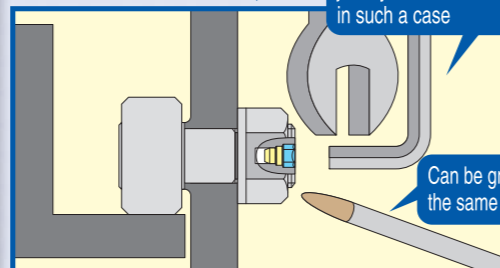

Can be greased in the same direction

No restriction for mounting location thanks to hexagon socket shape in stud head and thread side. Easy mounting and removal is available thanks to having hexagon socket shape in both side.

Conventional type (CF..A):
Cannot be mounted in a tight spot

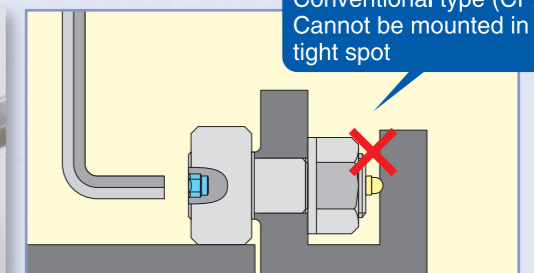

Installation can be completed even without any access of Allen wrench to the screw side

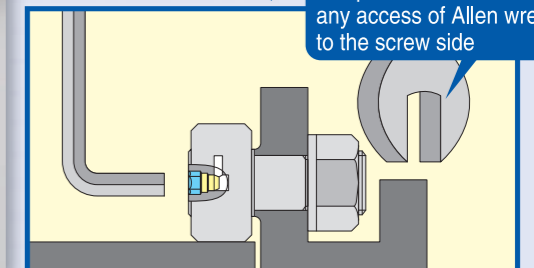

Type and Part Code

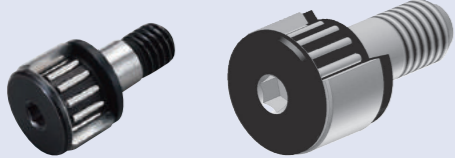
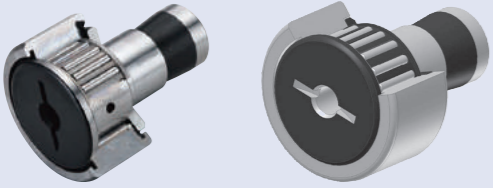
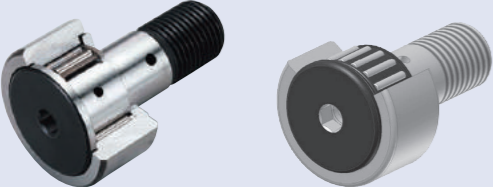
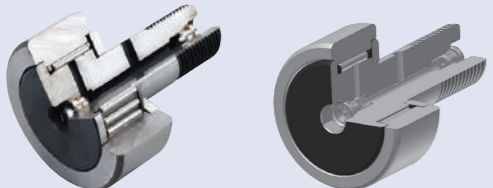
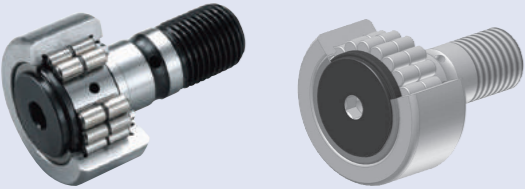
Type	Applicable axis diameter	Feature	Part Code
 <p>CFS Compact outer ring</p>	φ 2.5 ~ φ 6	Built-in very thin needle roller. Enables compact design due to very small outer ring diameter in comparison to stud diameter.	<p>CFS 6 V A</p> <p>Type Stud diameter</p> <p>V: Full complement None: With cage</p> <p>A: With hexagon socket on the stud head</p>
 <p>CF-SFU Easy mounting</p>	φ 6 ~ φ 20	A type with step on stud to allow easy mounting. Optimal for devices with limited space for stud tightening. Available with seal only.	<p>CF-SFU 16 V R</p> <p>Type Stud diameter</p> <p>V: Full complement None: With cage</p> <p>R: Crowned outer ring None: Cylindrical outer ring</p>
 <p>CF-A Hexagon hole</p>	φ 3 ~ φ 30	Hexagon sockets on the stud head. Easy mounting with hex-wrench. Available with hexagon sockets at the thread side mode (CF-B). (Applicable for shaft diameter 12 or more)	<p>V: Full complement None: With cage</p> <p>UU: With seal None: With shield</p> <p>CF 16 V UU R A N</p> <p>Type Stud diameter</p> <p>A: With hexagon socket on the stud head B: With hexagon socket on the thread side (Applicable for shaft diameter 12 or more)</p> <p>R: Crowned outer ring None: Cylindrical outer ring</p> <p>N: Option (Dedicated grease nipple)</p>
 <p>CF-AB</p>	φ 10 ~ φ 30	Both of stud head and thread ends have hexagon holes and integrated concave grease nipples. Available for mounting with either hexagon sockets and lubrication from both sides.	<p>V: Full complement None: With cage</p> <p>UU: With seal None: With shield</p> <p>CF 16 V UU R AB</p> <p>Type Stud diameter</p> <p>R: Crowned outer ring None: Cylindrical outer ring</p> <p>AB: With hexagon socket on both sides. (With integrated concave nipple)</p>
 <p>NUCF-AB</p>	φ 16 ~ φ 30	Cam follower which allows high radial loading and moderate axial loading with integrated cylindrical roller in double rows. Integrated concave grease nipples and hexagon sockets on both sides allow mounting and lubrication from either side.	<p>NUCF 16 R AB</p> <p>Type Stud diameter</p> <p>R: Crowned outer ring None: Cylindrical outer rings</p> <p>AB: With hexagon socket both sides. (With integrated concave nipple)</p>

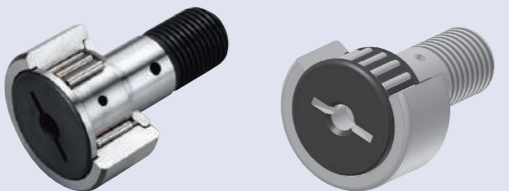
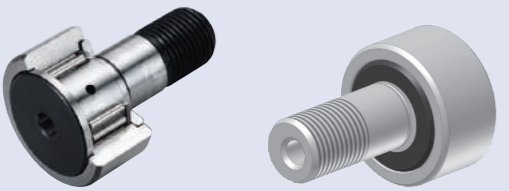
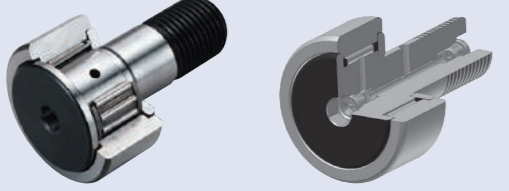
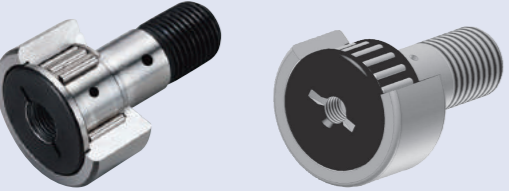
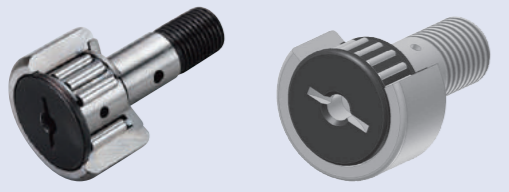
Type	Applicable axis diameter	Feature	Part Code
 <p>CF</p>	φ 5 ~ φ 30	General purpose cam follower with screwdriver groove on the stud head.	<p>V: Full complement None: With cage</p> <p>UU: With seal None: With shield</p> <p><u>CF</u> <u>16</u> <u>V</u> <u>UU</u> <u>R</u> <u>N</u></p> <p>↑ ↑ ↓ ↓ ↓ ↓ ↓</p> <p>Type Stud diameter R: Crowned outer ring Option None: Cylindrical outer ring (Dedicated grease nipple)</p>
 <p>CFH-A Hexagon socket, Eccentric</p>	φ 5 ~ φ 30	Available for the same mounting hole as general type. Compact and high accuracy eccentric cam followers with integrated structure enables easy fine positioning adjustment simply by rotating stud due to eccentric stud head shifting 0.2 to 1mm from stud mounting axis.	<p>V: Full complement None: With cage</p> <p>UU: With seal None: With shield</p> <p><u>CFH</u> <u>16</u> <u>V</u> <u>UU</u> <u>R</u> <u>A</u></p> <p>↑ ↑ ↓ ↓ ↓ ↓ ↓</p> <p>Type Stud diameter R: Crowned outer ring None: Cylindrical outer ring</p> <p>A: With hexagon socket on the stud head B: With hexagon socket on the thread side (Applicable for shaft diameter 12 or more)</p>
 <p>CFH-AB</p>	φ 12 ~ φ 30	Eccentric cam follower with integrated concave grease nipples on both sides. Available for mounting and lubrication with hexagon holes on both sides.	<p>V: Full complement None: With cage</p> <p>UU: With seal None: With shield</p> <p><u>CFH</u> <u>16</u> <u>V</u> <u>UU</u> <u>R</u> <u>AB</u></p> <p>↑ ↑ ↓ ↓ ↓ ↓ ↓</p> <p>Type Stud diameter R: Crowned outer ring None: Cylindrical outer ring</p> <p>AB: With hexagon socket on both sides (With integrated concave nipple)</p>
 <p>CFT Lubrication tap hole</p>	φ 6 ~ φ 30	Cam follower with tap for piping at stud head and thread of general type. Optimal for location that requires concentrated lubrication piping.	<p>V: Full complement None: With cage</p> <p>UU: With seal None: With shield</p> <p><u>CFT</u> <u>16</u> <u>V</u> <u>UU</u> <u>R</u> <u>A</u></p> <p>↑ ↑ ↓ ↓ ↓ ↓ ↓</p> <p>CFT: Standard typed CFHT: Eccentric type Stud diameter R: Crowned outer ring None: Cylindrical outer ring</p> <p>A: With hexagon socket on the stud head (Applicable shaft diameter φ 12 ~ φ 30) B: With hexagon socket on the thread side (Applicable shaft diameter φ 12 ~ φ 30) None: Standard type</p>
 <p>CR Inch type</p>	φ 4.826 ~ φ 22.225	Cam followers in inch dimension.	<p>R: Crowned outer ring None: Cylindrical outer ring</p> <p><u>CR</u> <u>16</u> <u>UU</u> <u>R</u></p> <p>↑ ↑ ↑ ↓</p> <p>Type Stud diameter UU: With seal None: With shield</p>

Structure and Features

Cam followers are compact and high rigid bearings with stud. It has a structure that an outer ring with built-in "roller" rolls over a track (raceway) and is utilized as guide roller for cam mechanism or linier motion. The cam follower is designed with a thick-walled outer ring in order to provide high rigidity to endure heavy load or impact load at contact portion with the track.

Outer rings have two shapes – crowned outer ring and cylindrical outer ring. The cylindrical outer ring is effective for heavy duty applications since it contacts with large contact area of the associated objects so that can mitigate the contact surface pressure. The crowned outer ring is suited for absorbing eccentric load since it absorbs angular misalignment due to a mount error. They have two internal structures – one with cage and one with full complement. Caged type cam followers are suited for high speed application, since the guiding feature of cage enables the rotation of "rollers" to be stable. Compared with caged type cam followers, full complement type is effective for applications with low-speed operation of heavy load due to its larger load rating. Full complement type also includes double-raw cylindrical roller type which allows moderate axial loading.

Cam followers shall be fixed by tightening hexagon nut at stud thread by holding the stud with screw driver or hex-wrench.

Cam followers with eccentric axis on the stud thread have an advantage to adjust the variation of mounting position within its eccentric range, without requesting high machining accuracy of mounting hole position.

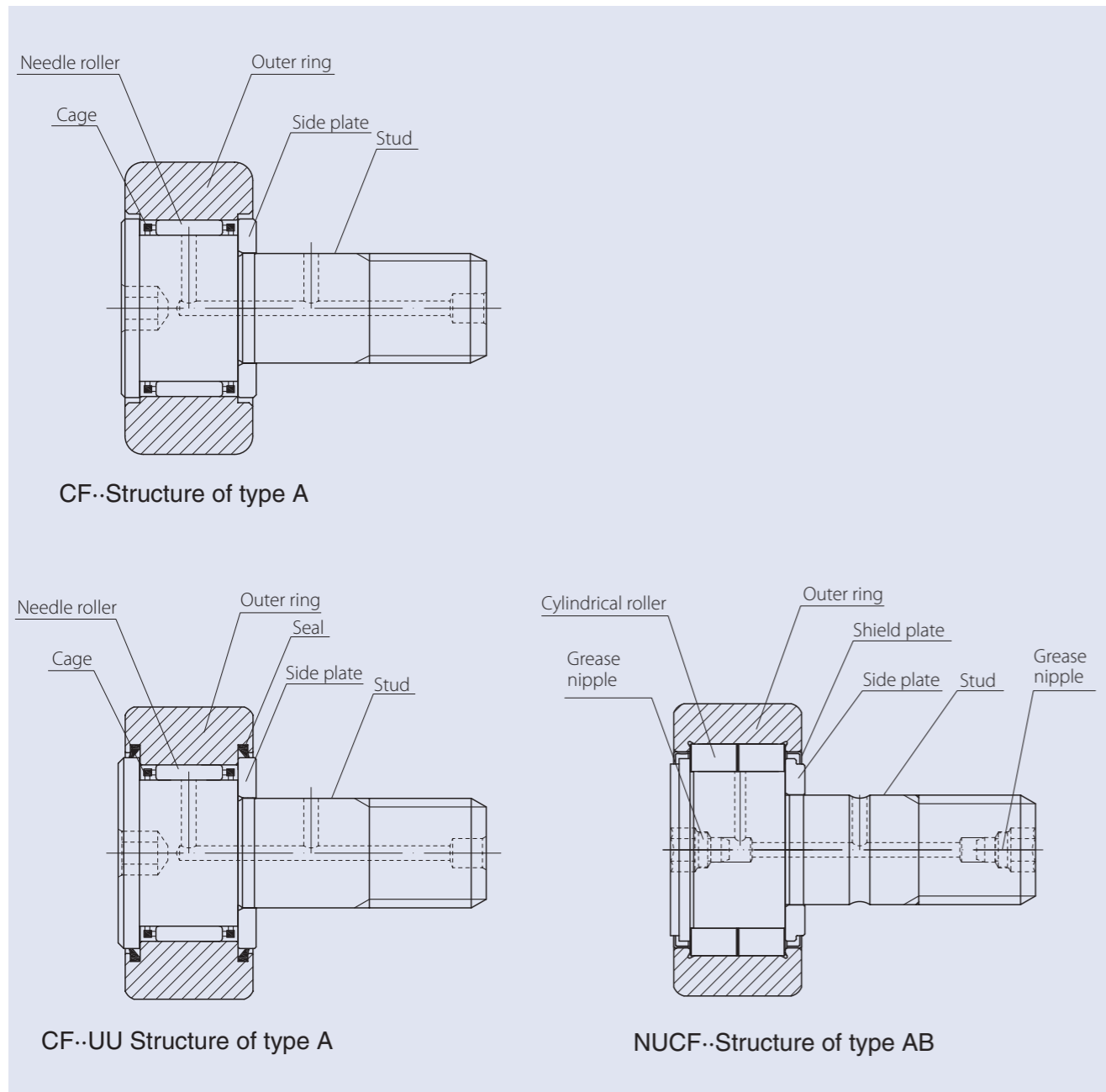

Accuracy standard

Accuracy of cam follower is indicated in Table-1 and Table-2 below.

Table-1 Accuracy

Unit: μm

Name	Category	Cam follower series in metric (CF--, NUCF--)		Compact type (CFS--)	Cam follower series in inch (CR--)	
		Crowned outer ring	Cylindrical outer ring	Cylindrical outer ring	Crowned outer ring	Cylindrical outer ring
Dimension tolerance of outer ring outer diameter (D)		0 -50	Refer to Table-2	Refer to Table-2	0 -50	0 -25
Dimension tolerance of stud diameter (d)		h7		h6	+25 0	
Dimension tolerance of outer ring width (C)		0 -120		0 -120	0 -130	

Table-2 Accuracy of outer ring (Metric series and compact type roller outer ring) Unit: μm

Nominal outer ring outer diameter D (mm)		Dimension tolerance of mean outside diameter in a single plane Δ_{Dmp}		Radial runout of outer ring K_{ea}
Over	Incl.	high	low	max.
6 (5 or more)	18	0	-8	15
18	30	0	-9	15
30	50	0	-11	20
50	80	0	-13	25
80	120	0	-15	35

Radial internal clearance

Table below indicates radial internal clearance of cam follower.

Table-3 Radial internal clearance

Unit: μm

Part code				Radial internal clearance	
Cam follower series in metric (CF)	Compact type (CFS)	Double-row cylindrical roller cam follower (NUCF)	Inch type series (CR)	min.	max.
CF3 ~ 5	CFS2.5 ~ 5		CR8 ~ 8-1	3	17
CF6 ~ 8	CFS6		CR10 ~ 10-2	5	20
CF10 ~ 12-1			CR12 ~ 22	5	25
CF16 ~ 20-1			CR24 ~ 26	10	30
CF24 ~ 30-2				10	40
		NUCF16 ~ 24		0	25
		NUCF24-1 ~ 30-2		5	30

Fits

Cam followers require machining of mounting hole to eliminate play at fitting portion especially for the portion which is subjected to impact shock due to its application in cantilevered mounting. Table-4 indicates recommended fits between cam follower and its mounting hole.

Table-4 Dimension tolerance of stud mounting hole

Part code	Dimension tolerance of stud mounting hole
Cam follower series in metric (CF)	H7
Compact type (CFS)	H6
Double-row cylindrical roller cam follower (NUCF)	H7
Cam follower series in inch (CR)	F7

Maximum permissible load

Permissible load of cam follower is subjected to change in accordance with bending strength and shear strength of its stud in addition to standard rating load of needle bearing due to its design with stud. This load is indicated as maximum permissible load.

Track load capacity

Track load capacity means a permissible load under which the outer ring of cam follower and the mating surface are allowable to be used over a long period without causing any deformation nor compression mark. Track load capacity depicted in dimension table indicates a value for which hardness of steel mating material is assumed to be HRC40. In the case that the hardness of mating material is not HRC40, track load capacity in the dimension table shall be multiplied by value of track load factor obtained by Figure-1.

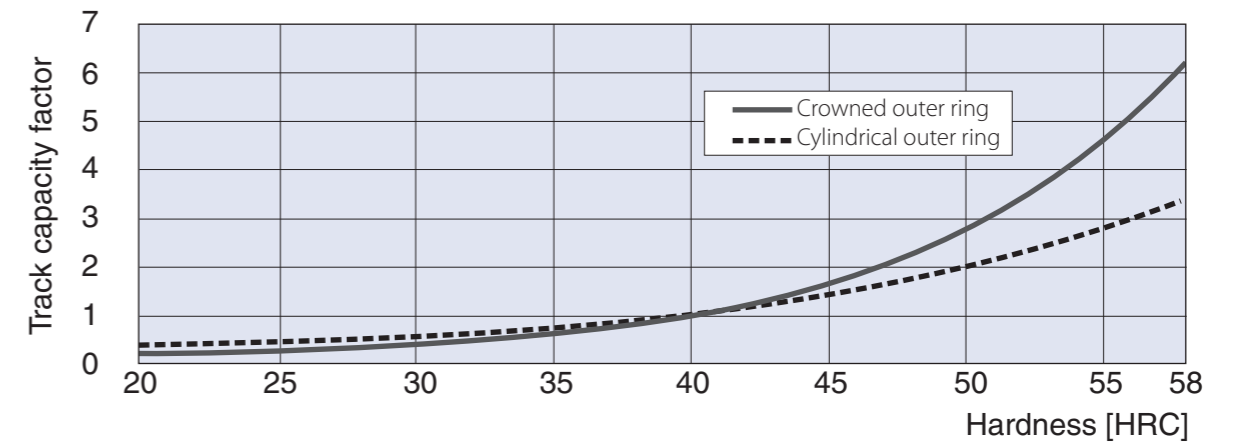

Figure-1 Track capacity factor

Lubrication

All the JNS cam followers are lubricated with pre-packed high quality lithium soap-based grease grade 2 (RoHS compliant) so that they are ready to use. For applications requiring high prevention measure against invasion of foreign matter or leakage of lubricant, products with seal(part conde--UU) which integrate special synthetic lubber with high abrasion resistance are also available.

Grease shall be packed up to volume approximately one-third to one-half of internal space of bearing. Lubrication interval varies depending on operation condition. Referential interval may be every six to twenty four months for cam followers with cages and every one to six months for full complement type with grease in the same type.

Some excessive grease may leak at the beginning of usage or immediately after re-greasing even for the products with seal. Aging operation period is recommended prior to application in which no contamination by grease is allowed in and around device. Wipe and clean any leaked extra grease after this operation.

Dedicated grease nipple shall be knocked in onto cam follower by pressing flange portion of the nipple using fixture shown in Figure-2.

Accessories

Accessories for cam follower of standard specification are shown in Table-5. Dedicated grease nipple is available upon customer request by ordering products with suffix "N" added to part code.

Also, type CF-AB and type NUCF-AB have integrated dedicated concave grease nipples installed at both sides.

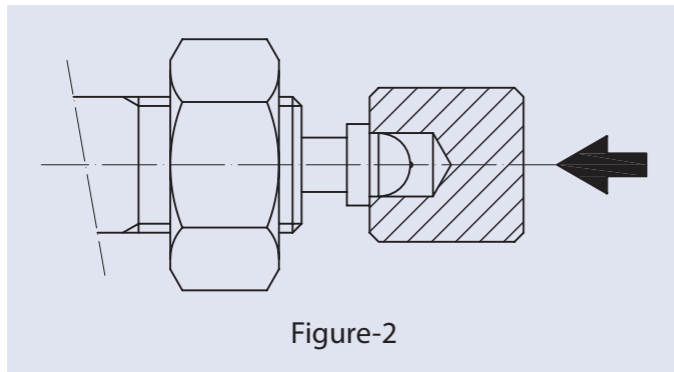





Figure-2

Example) CF 12 UUR -N
└─ Dedicated grease nipple

Table-5 Accessories

Part code		 Stop plug ^{*1)}	 Resin plug ^{*2)}	 Hexagon nuts style 2	Grease
CF CFH CR	Without seal	Attached	Attached	Attached	Packed
	With seal	Attached	Attached	Attached	Packed
CFT	Without seal	—	—	Attached	Packed
	With seal	—	—	Attached	Packed
CFS		—	—	Attached	Packed
CF-SFU		Attached	Attached	—	Packed
NUCF		—	—	Attached	Packed

*1) Stop plug is used for plugging unused lubrication hole(s).

*2) Resin plug is used for preventing leakage of grease.

DIMENSIONS OF GREASE NIPPLES

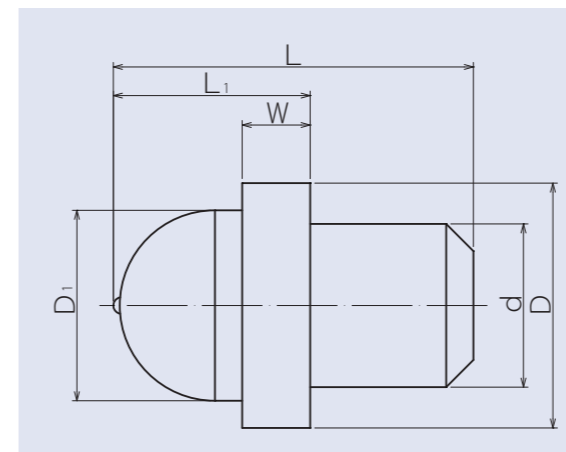

Table-6

Applicable part code	Nipple dimension					
	d	D	D ₁	L	L ₁	W
CF, CFH	d	D	D ₁	L	L ₁	W
CF5	3.2	7.5	6	9	5.5	1.5
CF6 ~ CF10-1	4	7.5	6	10	5.5	1.5
CF12 ~ CF18	6	8	6	11	6	2
CF20 ~ CF30-2	8	10	6	16	7	3

Dimensions of supply nozzle for CF..AB type

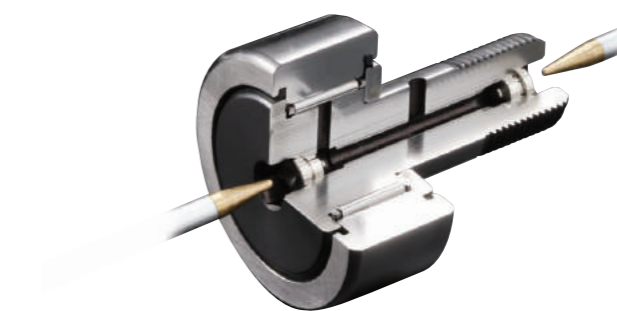

Table-7 Dimension of recommended lubrication nozzle (for CF..AB, NUCF..AB)

Type	Dimension and shape	Applied model number	
NPAB-1		CF10ABK(M10 × 1)	NUCF16AB
		CF10-1ABK(M10 × 1)	NUCF18AB
		CF12AB	
		CF12-1AB	
		CF16AB	
		CF18AB	
NPAB-2		CF20AB	NUCF20AB
		CF20-1AB	NUCF20-1AB
		CF24AB	NUCF24AB
		CF24-1AB	NUCF24-1AB
		CF30AB	NUCF30AB
		CF30-1AB	NUCF30-2AB

Mounting

Mounting part

Hole for stud shall be perpendicular to mounting surface so as to ensure even contact between outer ring and rolling surface of mating material. Corner chamfer of hole shall be as small as around C0.5. Counter bore diameter shall be dimension f or more as described in the dimension table.

Type CF-R with crowned outer ring is recommended in the case of application with insufficient contact between outer ring and rolling surface of mating material.

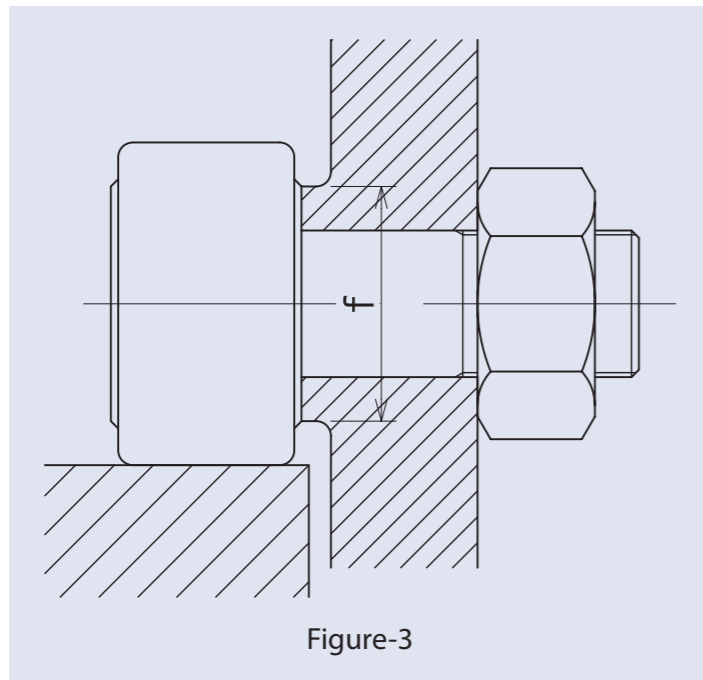

Figure-3

Mounting method

- Cam follower shall be mounted so as not to incline against direction of the motion.
- Mounting method to tighten cam follower directly to bracket by adding female thread to it without using nut as depicted in Figure-4 (A) is NOT recommended. This method may cause damage on stud due to concentration of bending stress in male thread portion in the event of loosening since it is difficult to tighten the stud sufficiently.

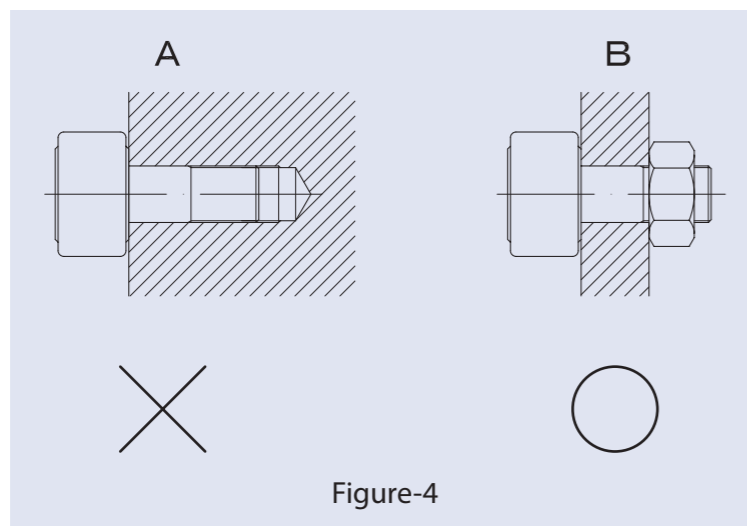

Figure-4

- For application with heavy load, lubrication hole of stud shall be located outside of loading range (on the side to receive load). Location of the lubrication hole is indicated by "JNS" marking on the side of stud flange. (Refer to Figure-5)
Hole at the center of stud is used as stopper for tightening or lubricant supply hole for grease lubrication.

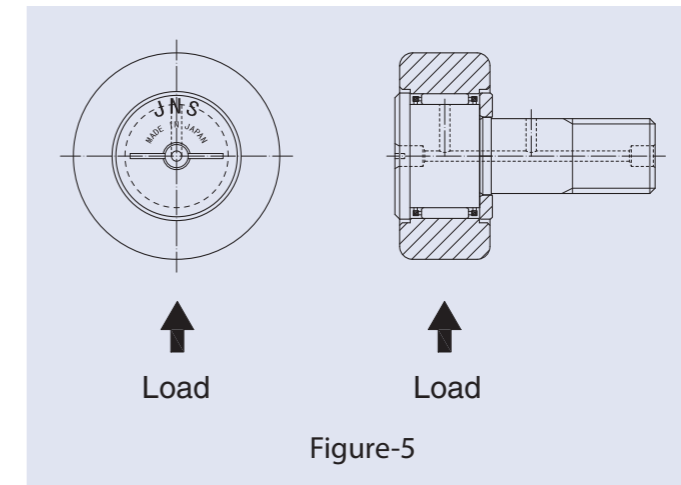

Figure-5

Precaution for using spring washer

It is important to ensure that spring washer used for mounting cam follower has no burr or sharp edge. Debris scraped from nut or mounting bracket by burr or sharp edge of washer during tightening can invade stud thread and can cause insufficient tightness or damage to thread.

Tightening torque of stud

Stud of cam follower is subjected to bending stress or tensile stress by bearing load. Tightening torque shall be set not to exceed the value in the dimension table.

Using double spring washers, double thin nut of JIS B 1181 or special nut with locking feature is recommended in the case of possible loosening of mounting screw due to vibration or impact shock.

Mounting of eccentric cam follower

Adjustment of eccentric shall be performed in accordance with the following procedure.

- (1) Insert stud to mounting hole and tighten nut as the stud can turn loosely. Marking of stud shall face location indicated in Figure-6 in relation to direction of load.
- (2) Gap between cam follower and mating contact surface may be adjusted by turning stud using hexagon hole on the stud head.
- (3) After completing adjustment, tighten nut with holding rotation of stud. Make it sure not to exceed maximum tightening torque of the nut.

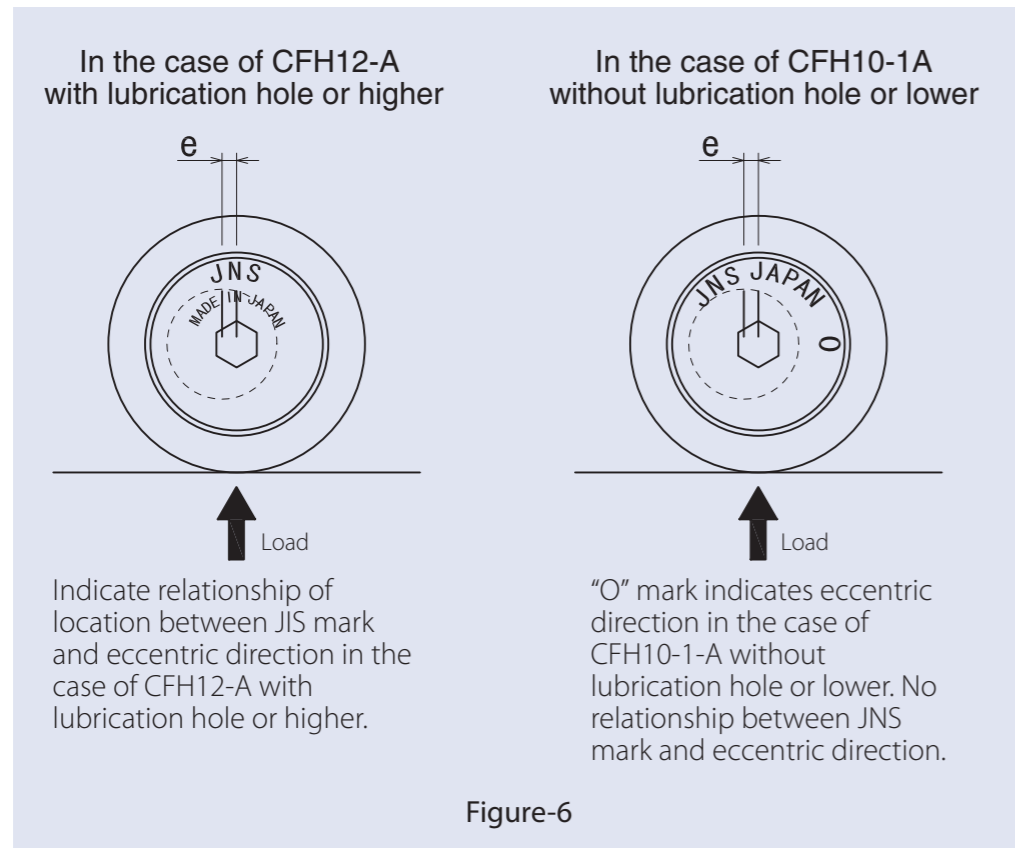

Mounting of CF-SFU type

Refer to Figure-7 for mounting method of easy mounting of CF-SFU type.

Type CF-SFU is NOT recommended for application in the part subjected to vibration or shock impact as much as its mounting is simple. Standard cam followers with nut are recommended for application with possible vibration or shock impact.

