

CFS..MA TYPE

Prepacked Grease

Stud diameter (mm)	Designation	Dimensions (mm)											Basic dynamic load rating	Basic static load rating	Largest permissible load	Max tightening torque	Mass
		Cylindrical outer ring		D	C	d	G	G1	B1	B2	C1	H					
h6 tolerance	With cage	Full roller															
2.5	CFS 2.5MA	—	5	3	2.5	M2.5×0.45	2.5	9.5	5	0.7	0.9	4.8	370	300	260	0.2	1
	0 -0.006	—											CFS 2.5VMA	920	990		
3	CFS 3MA	—	6	4	3	M3×0.5	3	11.5	6	0.7	1.5	5.8	570	560	360	0.3	2
	0 -0.006	—											CFS 3VMA	1 260	1 620		
4	CFS 4MA	—	8	5	4	M4×0.7	4	15	8	1	2	7.7	990	990	780	0.6	4
	0 -0.008	—											CFS 4VMA	2 160	2 790		
5	CFS 5MA	—	10	6	5	M5×0.8	5	18	10	1	2.5	9.6	1 440	1 710	1 420	1.3	7
	0 -0.008	—											CFS 5VMA	2 880	4 330		
6	CFS 6MA	—	12	7	6	M6×1	6	21.5	12	1.2	3	11.6	1 890	1 980	2 110	2.3	13
	0 -0.008	—											CFS 6VMA	4 240	5 760		

OUTER RINGS TOLERANCE (µm)

TYPE	Cylindrical outer ring
CFS2.5M,CFS3M,CFS4M,CFS5M,CFS6M	0/-8

ACCESSORIES

TYPE	
All types	NUT Attached



CF..MAB



CF..VMAB

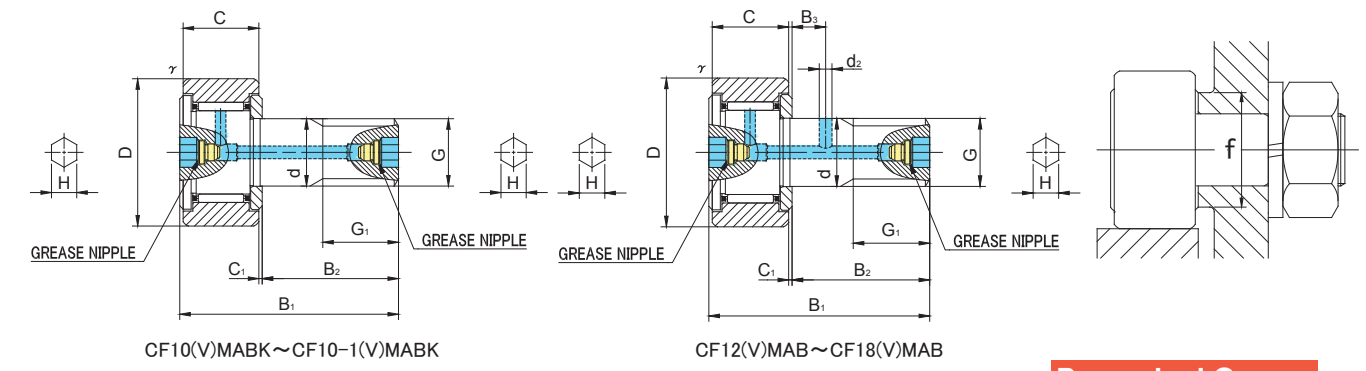

CF..MAB TYPE

Prepacked Grease

Stud diameter (mm)	h7 tolerance	Designation				Dimensions (mm)												Basic dynamic load rating	Basic static load rating	Largest permissible load	Limiting speed *	Track load capacity		Max tightening torque	Mass							
		Cylindrical outer ring		Crowned outer ring R500(CF10 ~ CF18)		D	C	d	G	G1	B1	B2	B3	C1	d2	H	r <sub>s</sub> min					f min	Cr N			Cor N	N	rpm	Cylindrical outer ring N	Crowned outer ring N	N·m	g (approx)
		Without seals	With seals	Without seals	With seals																											
10	0 -0.015	CF10MABK	CF10MUUABK	CF10MRABK	CF10MUURABK	22	12	10	M10×1	12	36	23	—	0.6	—	5	0.3	15	4 950	6 310	6 860	17 000	4 700	1 670	15	45						
		CF10VMABK	CF10VMUABK	CF10VMRABK	CF10VMURABK														8 740	13 340	7 450	7 500										
10	0 -0.015	CF10-1MABK	CF10-1MUUABK	CF10-1MRABK	CF10-1MUURABK	26	12	10	M10×1	12	36	23	—	0.6	—	5	0.3	15	4 950	6 310	6 860	17 000	5 490	2 060	15	60						
		CF10-1VMABK	CF10-1VMUABK	CF10-1VMRABK	CF10-1VMURABK														8 740	13 340	7 450	7 500										
12	0 -0.018	CF12MAB	CF12MUUAB	CF12MRAB	CF12MUURAB	30	14	12	M12×1.5	13	40	25	6	0.6	3	6	0.6	20	7 300	9 010	9 800	14 000	7 060	2 450	22	95						
		CF12VMAB	CF12VMUAB	CF12VMRAB	CF12VMURAB														12 350	18 120	11 270	6 000										
12	0 -0.018	CF12-1MAB	CF12-1MUUAB	CF12-1MRAB	CF12-1MUURAB	32	14	12	M12×1.5	13	40	25	6	0.6	3	6	0.6	20	7 300	9 010	9 800	14 000	7 450	2 740	22	105						
		CF12-1VMAB	CF12-1VMUAB	CF12-1VMRAB	CF12-1VMURAB														12 350	18 120	11 270	6 000										
16	0 -0.018	CF16MAB	CF16MUUAB	CF16MRAB	CF16MUURAB	35	18	16	M16×1.5	17	52	32.5	8	0.8	3	6	0.6	24	11 080	16 860	18 330	10 000	11 200	3 140	58	170						
		CF16VMAB	CF16VMUAB	CF16VMRAB	CF16VMURAB														19 020	34 610	19 800	4 500										
18	0 -0.018	CF18MAB	CF18MUUAB	CF18MRAB	CF18MUURAB	40	20	18	M18×1.5	19	58	36.5	8	0.8	3	6	1	26	13 520	23 180	25 200	8 500	14 400	3 720	87	250						
		CF18VMAB	CF18VMUAB	CF18VMRAB	CF18VMURAB														23 250	47 240	26 560	3 500										

CF..MAB TYPE has oil holes (grease nipple) which are prepared in the stud head and thread side, also an oil hole is prepared outer surface of stud.

\* Without seals, suitable for grease lubrication. In case of oil lubrication, up to 130% of this value shall be permissible, and 70% of this value shall apply for types with seals.

OUTER RINGS TOLERANCE (μm)

TYPE	Cylindrical outer ring	Crowned outer ring
CF10,CF10-1,CF12	0/-9	0/-50
CF12-1,CF16,CF18,CF20-1	0/-11	0/-50
CF20,CF24,CF24-1,CF30	0/-13	0/-50
CF30-1,CF30-2	0/-15	0/-50

ACCESSORIES

TYPE	Installed	Attached
Grease Nipple		
NUT		



CF..MAB



CF..VMAB

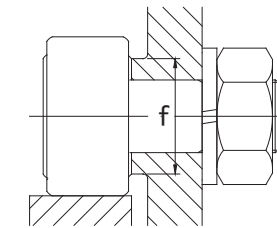
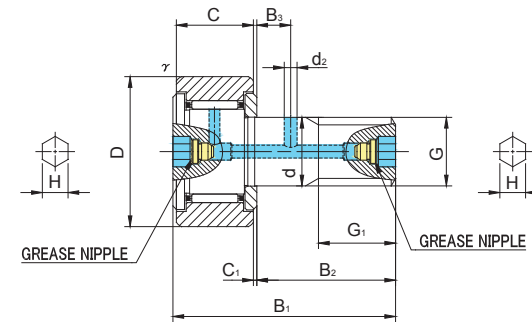

CF..MAB TYPE

Prepacked Grease

Stud diameter (mm)	Designation	Dimensions (mm)															Basic dynamic load rating	Basic static load rating	Largest permissible load	Limiting speed *	Track load capacity		Max tightening torque	Mass	
		Cylindrical outer ring				Crowned outer ring R1000(CF20 ≤)				Other dimensions											Cylindrical outer ring N	Crowned outer ring N			N-m
h7 tolerance	Without seals	With seals	Without seals	With seals	D	C	d	G	G1	B1	B2	B3	C1	d2	H	r <sub>s</sub> min	f min	Cr N	Cor N	N	rpm	N	N	N-m	g (approx)
20	CF20MAB	CF20MUAB	CF20MRAB	CF20MUURAB	52	24	20	M20×1.5	21	66	40.5	9	0.8	4	8	1	36	19 020	31 830	32 140	7 000	23 200	8 230	120	460
	CF20VMAB	CF20VMUAB	CF20VMRAB	CF20VMUURAB														30 470	59 320	32 140	3 500				
20	CF20-1MAB	CF20-1MUAB	CF20-1MRAB	CF20-1MUURAB	47	24	20	M20×1.5	21	66	40.5	9	0.8	4	8	1	36	19 020	31 830	32 140	7 000	21 000	7 150	120	385
	CF20-1VMAB	CF20-1VMUAB	CF20-1VMRAB	CF20-1VMUURAB														30 470	59 320	32 140	3 500				
24	CF24MAB	CF24MUAB	CF24MRAB	CF24MUURAB	62	29	24	M24×1.5	25	80	49.5	11	0.8	4	8	1	40	28 040	48 410	49 500	6 500	34 200	10 500	220	815
	CF24VMAB	CF24VMUAB	CF24VMRAB	CF24VMUURAB														42 820	84 650	49 500	3 000				
24	CF24-1MAB	CF24-1MUAB	CF24-1MRAB	CF24-1MUURAB	72	29	24	M24×1.5	25	80	49.5	11	0.8	4	8	1	40	28 040	48 410	49 500	6 500	39 800	12 900	220	1 140
	CF24-1VMAB	CF24-1VMUAB	CF24-1VMRAB	CF24-1VMUURAB														42 820	84 650	49 500	3 000				
30	CF30MAB	CF30MUAB	CF30MRAB	CF30MUURAB	80	35	30	M30×1.5	32	100	63	15	1	4	8	1	46	41 740	78 250	73 700	5 000	52 600	14 900	450	1 870
	CF30VMAB	CF30VMUAB	CF30VMRAB	CF30VMUURAB														62 210	132 530	73 700	2 200				
30	CF30-1MAB	CF30-1MUAB	CF30-1MRAB	CF30-1MUURAB	85	35	30	M30×1.5	32	100	63	15	1	4	8	1	46	41 740	78 250	73 700	5 000	56 000	16 100	450	2 030
	CF30-1VMAB	CF30-1VMUAB	CF30-1VMRAB	CF30-1VMUURAB														62 210	132 530	73 700	2 200				
30	CF30-2MAB	CF30-2MUAB	CF30-2MRAB	CF30-2MUURAB	90	35	30	M30×1.5	32	100	63	15	1	4	8	1	46	41 740	78 250	73 700	5 000	59 300	17 300	450	2 220
	CF30-2VMAB	CF30-2VMUAB	CF30-2VMRAB	CF30-2VMUURAB														62 210	132 530	73 700	2 200				

CF..MAB TYPE has oil holes (grease nipple) which are prepared in the stud head and thread side, also an oil hole is prepared outer surface of stud.

\* Without seals, suitable for grease lubrication. In case of oil lubrication, up to 130% of this value shall be permissible, and 70% of this value shall apply for types with seals.

OUTER RINGS TOLERANCE (µm)

TYPE	Cylindrical outer ring	Crowned outer ring
CF10,CF10-1,CF12	0/-9	0/-50
CF12-1,CF16,CF18,CF20-1	0/-11	0/-50
CF20,CF24,CF24-1,CF30	0/-13	0/-50
CF30-1,CF30-2	0/-15	0/-50

ACCESSORIES

TYPE	Grease Nipple	NUT
All types	Installed	Attached

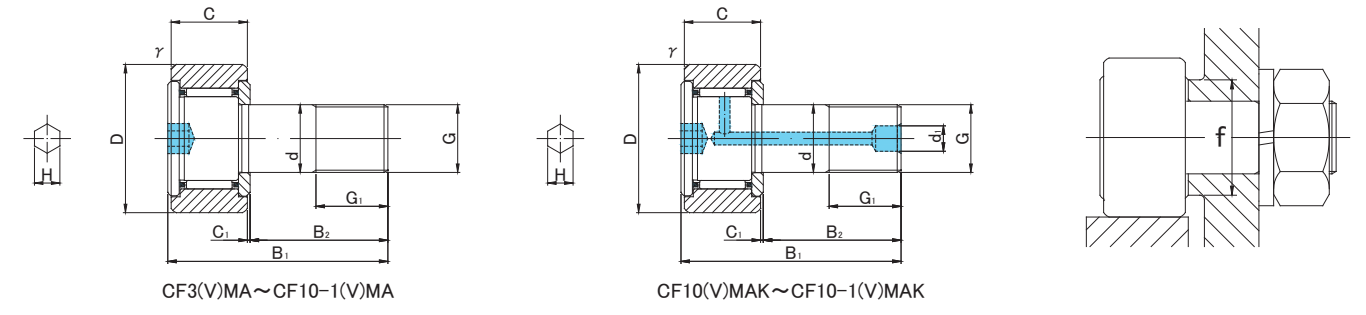
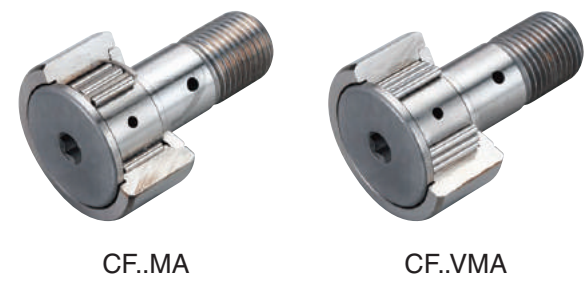

CF..MA TYPE

Prepacked Grease

Stud diameter (mm)	h7 tolerance	Designation				Dimensions (mm)													Basic dynamic load rating Cr N	Basic static load rating Cor N	Largest permissible load N	Limiting speed * rpm	Track load capacity		Max tightening torque N·m	Mass g (approx)	
		Cylindrical outer ring		Crowned outer ring R250(CF3 ~ CF5) R500(CF6 ~ CF10-1)		D	C	d	G	G1	B1	B2	B3	C1	d1	d2	H	rs min					f min	Cylindrical outer ring N			Crowned outer ring N
		Without seals	With seals	Without seals	With seals																						
3	0 -0.010	CF 3MA	CF 3MUUA	CF 3MRA	CF 3MUURA	10	7	3	M3×0.5	5	17	9	—	0.5	—	—	1.5	0.2	6.8	1 350	1 080	360	47 000	1 370	370	0.4	4.5
		CF 3VMA	CF 3VMUUA	CF 3VMRA	CF 3VMUURA															2 570	2 300	360	18 800				
4	0 -0.012	CF 4MA	CF 4MUUA	CF 4MRA	CF 4MUURA	12	8	4	M4×0.7	6	20	11	—	0.5	—	—	2	0.3	8.6	1 890	1 880	780	37 000	1 760	470	1	7.5
		CF 4VMA	CF 4VMUUA	CF 4VMRA	CF 4VMUURA															3 680	3 950	780	14 800				
5	0 -0.012	CF 5MA	CF 5MUUA	CF 5MRA	CF 5MUURA	13	9	5	M5×0.8	7.5	23	13	—	0.5	—	—	2.5	0.3	9.7	2 880	2 540	1 420	29 000	2 250	530	2	10.5
		CF 5VMA	CF 5VMUUA	CF 5VMRA	CF 5VMUURA															4 690	5 060	1 420	11 600				
6	0 -0.012	CF 6MA	CF 6MUUA	CF 6MRA	CF 6MUURA	16	11	6	M6×1	8	28	16	—	0.6	—	—	3	0.3	11	3 330	3 330	2 110	25 000	3 430	1 080	3	18.5
		CF 6VMA	CF 6VMUUA	CF 6VMRA	CF 6VMUURA															6 400	7 840	2 110	12 000				
8	0 -0.015	CF 8MA	CF 8MUUA	CF 8MRA	CF 8MUURA	19	11	8	M8×1.25	10	32	20	—	0.6	—	—	4	0.3	13	3 960	4 330	4 710	20 000	4 020	1 370	8	28.5
		CF 8VMA	CF 8VMUUA	CF 8VMRA	CF 8VMUURA															7 470	10 270	4 710	9 000				
10	0 -0.015	CF10MA	CF10MUUA	CF10MRA	CF10MUURA	22	12	10	M10×1.25	12	36	23	—	0.6	—	—	5	0.3	15	4 950	6 310	6 860	17 000	4 700	1 670	15	45
		CF10VMA	CF10VMUUA	CF10VMRA	CF10VMUURA															8 740	13 340	7 450	7 500				
10	0 -0.015	CF10-1MA	CF10-1MUUA	CF10-1MRA	CF10-1MUURA	26	12	10	M10×1.25	12	36	23	—	0.6	—	—	5	0.3	15	4 950	6 310	6 860	17 000	5 490	2 060	15	60
		CF10-1VMA	CF10-1VMUUA	CF10-1VMRA	CF10-1VMUURA															8 740	13 340	7 450	7 500				
10	0 -0.015	CF10MAK	CF10MUUAK	CF10MRAK	CF10MUURAK	22	12	10	M10×1	12	36	23	—	0.6	4	—	5	0.3	15	4 950	6 310	6 860	17 000	4 700	1 670	15	45
		CF10VMAK	CF10VMUAK	CF10VMRAK	CF10VMUURAK															8 740	13 340	7 450	7 500				
10	0 -0.015	CF10-1MAK	CF10-1MUUAK	CF10-1MRAK	CF10-1MUURAK	26	12	10	M10×1	12	36	23	—	0.6	4	—	5	0.3	15	4 950	6 310	6 860	17 000	5 490	2 060	15	60
		CF10-1VMAK	CF10-1VMUAK	CF10-1VMRAK	CF10-1VMUURAK															8 740	13 340	7 450	7 500				

\* Without seals, suitable for grease lubrication. In case of oil lubrication, up to 130% of this value shall be permissible, and 70% of this value shall apply for types with seals.

OUTER RINGS TOLERANCE (µm)

TYPE	Cylindrical outer ring	Crowned outer ring
CF3M,CF4M,CF5M,CF6M	0/-8	0/-50
CF8M,CF10M,CF10-1M,CF12M	0/-9	0/-50
CF12-1M,CF16M,CF18M,CF20-1M	0/-11	0/-50
CF20M,CF24M,CF24-1M,CF30M	0/-13	0/-50
CF30-1M,CF30-2M	0/-15	0/-50

ACCESSORIES

TYPE	STOP PLUG	RESIN PLUG	NUT
CF3M/CF4M/CF5M/CF6M/CF8M/CF10M/CF10-1M	—	—	Attached
CF10MK/CF10-1MK	φ 4 Attached	φ 4 Attached	Attached
CF12M/CF12-1M/CF16M/CF18M	φ 6 Attached	φ 6 Attached	Attached
CF20M/CF20-1M/CF24M/CF24-1M/CF30M/CF30-1M/CF30-2M	φ 8 Attached	φ 8 Attached	Attached





CF..MA



CF..VMA

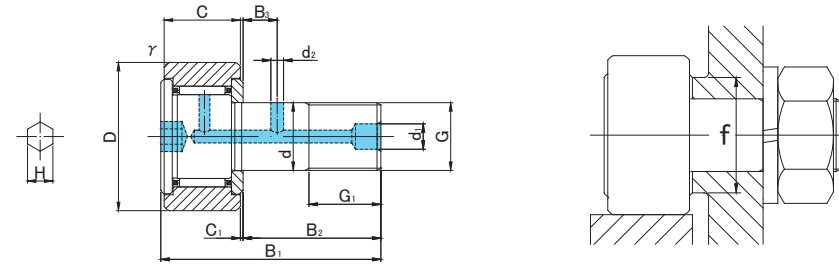

CF..MA TYPE

Prepacked Grease

Stud diameter (mm)	h7 tolerance	Designation				Dimensions (mm)													Basic dynamic load rating	Basic static load rating	Largest permissible load	Limiting speed *	Track load capacity		Max tightening torque	Mass							
		Cylindrical outer ring		Crowned outer ring R500(CF12 ~ CF18) R1000(CF20 ≤)		D	C	d	G	G1	B1	B2	B3	C1	d1	d2	H	rs min					f min	Cr N			Cor N	N	rpm	Cylindrical outer ring N	Crowned outer ring N	N·m	g (approx)
		Without seals	With seals	Without seals	With seals																												
12	0 -0.018	CF12MA	CF12MUUA	CF12MRA	CF12MUURA	30	14	12	M12×1.5	13	40	25	6	0.6	6	3	6	0.6	20	7 300	9 010	9 800	14 000	7 060	2 450	22	95						
		CF12VMA	CF12VMUUA	CF12VMRA	CF12VMUURA															12 350	18 120	11 270	6 000										
12	0 -0.018	CF12-1MA	CF12-1MUUA	CF12-1MRA	CF12-1MUURA	32	14	12	M12×1.5	13	40	25	6	0.6	6	3	6	0.6	20	7 300	9 010	9 800	14 000	7 450	2 740	22	105						
		CF12-1VMA	CF12-1VMUUA	CF12-1VMRA	CF12-1VMUURA															12 350	18 120	11 270	6 000										
16	0 -0.018	CF16MA	CF16MUUA	CF16MRA	CF16MUURA	35	18	16	M16×1.5	17	52	32.5	8	0.8	6	3	6	0.6	24	11 080	16 860	18 330	10 000	11 200	3 140	58	170						
		CF16VMA	CF16VMUUA	CF16VMRA	CF16VMUURA															19 020	34 610	19 800	4 500										
18	0 -0.018	CF18MA	CF18MUUA	CF18MRA	CF18MUURA	40	20	18	M18×1.5	19	58	36.5	8	0.8	6	3	6	1	26	13 520	23 180	25 200	8 500	14 400	3 720	87	250						
		CF18VMA	CF18VMUUA	CF18VMRA	CF18VMUURA															23 250	47 240	26 560	3 500										
20	0 -0.021	CF20MA	CF20MUUA	CF20MRA	CF20MUURA	52	24	20	M20×1.5	21	66	40.5	9	0.8	8	4	8	1	36	19 020	31 830	32 140	7 000	23 200	8 230	120	460						
		CF20VMA	CF20VMUUA	CF20VMRA	CF20VMUURA															30 470	59 320	32 140	3 500										
20	0 -0.021	CF20-1MA	CF20-1MUUA	CF20-1MRA	CF20-1MUURA	47	24	20	M20×1.5	21	66	40.5	9	0.8	8	4	8	1	36	19 020	31 830	32 140	7 000	21 000	7 150	120	385						
		CF20-1VMA	CF20-1VMUUA	CF20-1VMRA	CF20-1VMUURA															30 470	59 320	32 140	3 500										
24	0 -0.021	CF24MA	CF24MUUA	CF24MRA	CF24MUURA	62	29	24	M24×1.5	25	80	49.5	11	0.8	8	4	8	1	40	28 040	48 410	49 500	6 500	34 200	10 500	220	815						
		CF24VMA	CF24VMUUA	CF24VMRA	CF24VMUURA															42 820	84 650	49 500	3 000										
24	0 -0.021	CF24-1MA	CF24-1MUUA	CF24-1MRA	CF24-1MUURA	72	29	24	M24×1.5	25	80	49.5	11	0.8	8	4	8	1	40	28 040	48 410	49 500	6 500	39 800	12 900	220	1 140						
		CF24-1VMA	CF24-1VMUUA	CF24-1VMRA	CF24-1VMUURA															42 820	84 650	49 500	3 000										
30	0 -0.021	CF30MA	CF30MUUA	CF30MRA	CF30MUURA	80	35	30	M30×1.5	32	100	63	15	1	8	4	8	1	46	41 740	78 250	73 700	5 000	52 600	14 900	450	1 870						
		CF30VMA	CF30VMUUA	CF30VMRA	CF30VMUURA															62 210	132 530	73 700	2 200										
30	0 -0.021	CF30-1MA	CF30-1MUUA	CF30-1MRA	CF30-1MUURA	85	35	30	M30×1.5	32	100	63	15	1	8	4	8	1	46	41 740	78 250	73 700	5 000	56 000	16 100	450	2 030						
		CF30-1VMA	CF30-1VMUUA	CF30-1VMRA	CF30-1VMUURA															62 210	132 530	73 700	2 200										
30	0 -0.021	CF30-2MA	CF30-2MUUA	CF30-2MRA	CF30-2MUURA	90	35	30	M30×1.5	32	100	63	15	1	8	4	8	1	46	41 740	78 250	73 700	5 000	59 300	17 300	450	2 220						
		CF30-2VMA	CF30-2VMUUA	CF30-2VMRA	CF30-2VMUURA															62 210	132 530	73 700	2 200										

\* Without seals, suitable for grease lubrication. In case of oil lubrication, up to 130% of this value shall be permissible, and 70% of this value shall apply for types with seals.

OUTER RINGS TOLERANCE (µm)

TYPE	Cylindrical outer ring	Crowned outer ring
CF3M,CF4M,CF5M,CF6M	0/-8	0/-50
CF8M,CF10M,CF10-1M,CF12M	0/-9	0/-50
CF12-1M,CF16M,CF18M,CF20-1M	0/-11	0/-50
CF20M,CF24M,CF24-1M,CF30M	0/-13	0/-50
CF30-1M,CF30-2M	0/-15	0/-50

ACCESSORIES

TYPE	STOP PLUG	RESIN PLUG	NUT
CF3M/CF4M/CF5M/CF6M/CF8M/CF10M/CF10-1M	—	—	Attached
CF10MK/CF10-1MK	φ 4 Attached	φ 4 Attached	Attached
CF12M/CF12-1M/CF16M/CF18M	φ 6 Attached	φ 6 Attached	Attached
CF20M/CF20-1M/CF24M/CF24-1M/CF30M/CF30-1M/CF30-2M	φ 8 Attached	φ 8 Attached	Attached

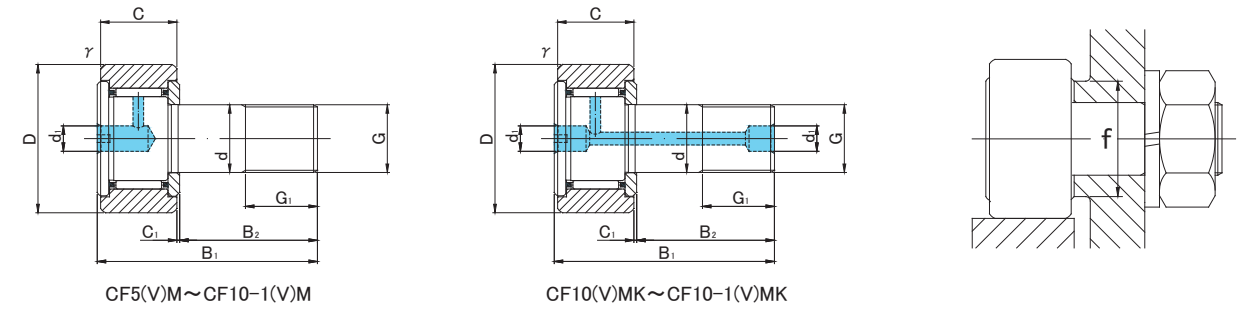
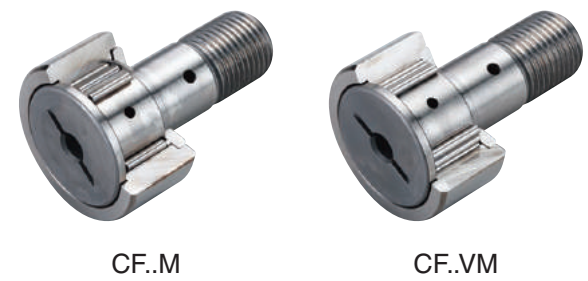
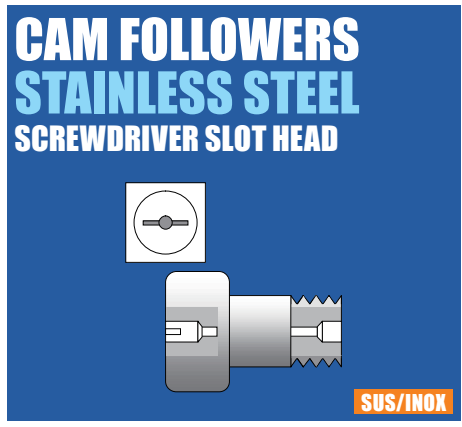

CF..M TYPE

Prepacked Grease

Stud diameter (mm)	Designation				Dimensions (mm)													Basic dynamic load rating	Basic static load rating	Largest permissible load	Limiting speed *	Track load capacity		Max tightening torque	Mass	
	Cylindrical outer ring		Crowned outer ring R250(CF5) R500(CF6 ~ CF10-1)		D	C	d	G	G1	B1	B2	B3	C1	d1	d2	r <sub>s</sub> min	f min					Cr N	Cor N			N
h7 tolerance	Without seals	With seals	Without seals	With seals																						
5	0 -0.012	CF 5M	CF 5MUU	CF 5MR	CF 5MUUR	13	9	5	M5×0.8	7.5	23	13	—	0.5	3.1	—	0.3	9.7	2 880	2 540	1 420	29 000	2 250	530	2	10.5
		CF 5VM	CF 5VMUU	CF 5VMR	CF 5VMUUR														4 690	5 060	1 420	11 600				
6	0 -0.012	CF 6M	CF 6MUU	CF 6MR	CF 6MUUR	16	11	6	M6×1	8	28	16	—	0.6	4	—	0.3	11	3 330	3 330	2 110	25 000	3 430	1 080	3	18.5
		CF 6VM	CF 6VMUU	CF 6VMR	CF 6VMUUR														6 400	7 840	2 110	12 000				
8	0 -0.015	CF 8M	CF 8MUU	CF 8MR	CF 8MUUR	19	11	8	M8×1.25	10	32	20	—	0.6	4	—	0.3	13	3 960	4 330	4 710	20 000	4 020	1 370	8	28.5
		CF 8VM	CF 8VMUU	CF 8VMR	CF 8VMUUR														7 470	10 270	4 710	9 000				
10	0 -0.015	CF10M	CF10MUU	CF10MR	CF10MUUR	22	12	10	M10×1.25	12	36	23	—	0.6	4	—	0.3	15	4 950	6 310	6 860	17 000	4 700	1 670	15	45
		CF10VM	CF10VMUU	CF10VMR	CF10VMUUR														8 740	13 340	7 450	7 500				
10	0 -0.015	CF10-1M	CF10-1MUU	CF10-1MR	CF10-1MUUR	26	12	10	M10×1.25	12	36	23	—	0.6	4	—	0.3	15	4 950	6 310	6 860	17 000	5 490	2 060	15	60
		CF10-1VM	CF10-1VMUU	CF10-1VMR	CF10-1VMUUR														8 740	13 340	7 450	7 500				
10	0 -0.015	CF10MK	CF10MUUK	CF10MRK	CF10MUURK	22	12	10	M10×1	12	36	23	—	0.6	4	—	0.3	15	4 950	6 310	6 860	17 000	4 700	1 670	15	45
		CF10VMK	CF10VMUUK	CF10VMRK	CF10VMUURK														8 740	13 340	7 450	7 500				
10	0 -0.015	CF10-1MK	CF10-1MUUK	CF10-1MRK	CF10-1MUURK	26	12	10	M10×1	12	36	23	—	0.6	4	—	0.3	15	4 950	6 310	6 860	17 000	5 490	2 060	15	60
		CF10-1VMK	CF10-1VMUUK	CF10-1VMRK	CF10-1VMUURK														8 740	13 340	7 450	7 500				

\* Without seals, suitable for grease lubrication. In case of oil lubrication, up to 130% of this value shall be permissible, and 70% of this value shall apply for types with seals.

OUTER RINGS TOLERANCE (μm)

TYPE	Cylindrical outer ring	Crowned outer ring
CF5M,CF6M	0/-8	0/-50
CF8M,CF10M,CF10-1M,CF12M	0/-9	0/-50
CF12-1M,CF16M,CF18M,CF20-1M	0/-11	0/-50
CF20M,CF24M,CF24-1M,CF30M	0/-13	0/-50
CF30-1M,CF30-2M	0/-15	0/-50

ACCESSORIES

TYPE	STOP PLUG	RESIN PLUG	NUT
CF5M	—	—	Attached
CF6M/CF8M/CF10M/CF10-1M	—	φ 4 Attached	Attached
CF10MK/CF10-1MK	φ 4 Attached	φ 4 Attached	Attached
CF12M/CF12-1M/CF16M/CF18M	φ 6 Attached	φ 6 Attached	Attached
CF20M/CF20-1M/CF24M/CF24-1M/CF30M/CF30-1M/CF30-2M	φ 8 Attached	φ 8 Attached	Attached

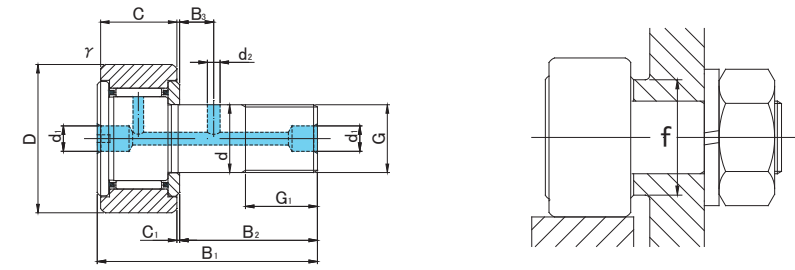
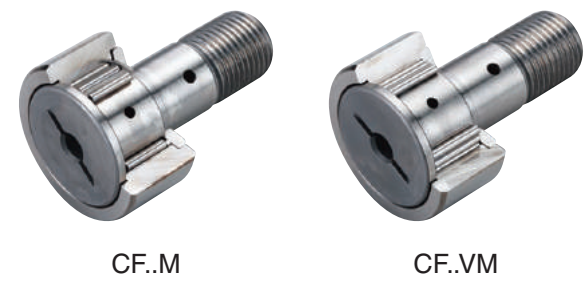

CF..M TYPE

Prepacked Grease

Stud diameter (mm)	h7 tolerance	Designation				Dimensions (mm)													Basic dynamic load rating Cr N	Basic static load rating Cor N	Largest permissible load N	Limiting speed * rpm	Track load capacity		Max tightening torque N-m	Mass g (approx)
		Cylindrical outer ring		Crowned outer ring R500(CF12 ~ CF18) R1000(CF20 ≤)		D	C	d	G	G1	B1	B2	B3	C1	d1	d2	rs min	f min					Cylindrical outer ring N	Crowned outer ring N		
		Without seals	With seals	Without seals	With seals																					
12	0 -0.018	CF12M	CF12MUU	CF12MR	CF12MUUR	30	14	12	M12×1.5	13	40	25	6	0.6	6	3	0.6	20	7 300	9 010	9 800	14 000	7 060	2 450	22	95
		CF12VM	CF12VMUU	CF12VMR	CF12VMUUR														12 350	18 120	11 270	6 000				
12	0 -0.018	CF12-1M	CF12-1MUU	CF12-1MR	CF12-1MUUR	32	14	12	M12×1.5	13	40	25	6	0.6	6	3	0.6	20	7 300	9 010	9 800	14 000	7 450	2 740	22	105
		CF12-1VM	CF12-1VMUU	CF12-1VMR	CF12-1VMUUR														12 350	18 120	11 270	6 000				
16	0 -0.018	CF16M	CF16MUU	CF16MR	CF16MUUR	35	18	16	M16×1.5	17	52	32.5	8	0.8	6	3	0.6	24	11 080	16 860	18 330	10 000	11 200	3 140	58	170
		CF16VM	CF16VMUU	CF16VMR	CF16VMUUR														19 020	34 610	19 800	4 500				
18	0 -0.018	CF18M	CF18MUU	CF18MR	CF18MUUR	40	20	18	M18×1.5	19	58	36.5	8	0.8	6	3	1	26	13 520	23 180	25 200	8 500	14 400	3 720	87	250
		CF18VM	CF18VMUU	CF18VMR	CF18VMUUR														23 250	47 240	26 560	3 500				
20	0 -0.021	CF20M	CF20MUU	CF20MR	CF20MUUR	52	24	20	M20×1.5	21	66	40.5	9	0.8	8	4	1	36	19 020	31 830	32 140	7 000	23 200	8 230	120	460
		CF20VM	CF20VMUU	CF20VMR	CF20VMUUR														30 470	59 320	32 140	3 500				
20	0 -0.021	CF20-1M	CF20-1MUU	CF20-1MR	CF20-1MUUR	47	24	20	M20×1.5	21	66	40.5	9	0.8	8	4	1	36	19 020	31 830	32 140	7 000	21 000	7 150	120	385
		CF20-1VM	CF20-1VMUU	CF20-1VMR	CF20-1VMUUR														30 470	59 320	32 140	3 500				
24	0 -0.021	CF24M	CF24MUU	CF24MR	CF24MUUR	62	29	24	M24×1.5	25	80	49.5	11	0.8	8	4	1	40	28 040	48 410	49 500	6 500	34 200	10 500	220	815
		CF24VM	CF24VMUU	CF24VMR	CF24VMUUR														42 820	84 650	49 500	3 000				
24	0 -0.021	CF24-1M	CF24-1MUU	CF24-1MR	CF24-1MUUR	72	29	24	M24×1.5	25	80	49.5	11	0.8	8	4	1	40	28 040	48 410	49 500	6 500	39 800	12 900	220	1 140
		CF24-1VM	CF24-1VMUU	CF24-1VMR	CF24-1VMUUR														42 820	84 650	49 500	3 000				
30	0 -0.021	CF30M	CF30MUU	CF30MR	CF30MUUR	80	35	30	M30×1.5	32	100	63	15	1	8	4	1	46	41 740	78 250	73 700	5 000	52 600	14 900	450	1 870
		CF30VM	CF30VMUU	CF30VMR	CF30VMUUR														62 210	132 530	73 700	2 200				
30	0 -0.021	CF30-1M	CF30-1MUU	CF30-1MR	CF30-1MUUR	85	35	30	M30×1.5	32	100	63	15	1	8	4	1	46	41 740	78 250	73 700	5 000	56 000	16 100	450	2 030
		CF30-1VM	CF30-1VMUU	CF30-1VMR	CF30-1VMUUR														62 210	132 530	73 700	2 200				
30	0 -0.021	CF30-2M	CF30-2MUU	CF30-2MR	CF30-2MUUR	90	35	30	M30×1.5	32	100	63	15	1	8	4	1	46	41 740	78 250	73 700	5 000	59 300	17 300	450	2 220
		CF30-2VM	CF30-2VMUU	CF30-2VMR	CF30-2VMUUR														62 210	132 530	73 700	2 200				

\* Without seals, suitable for grease lubrication. In case of oil lubrication, up to 130% of this value shall be permissible, and 70% of this value shall apply for types with seals.

OUTER RINGS TOLERANCE (μm)

TYPE	Cylindrical outer ring	Crowned outer ring
CF5M,CF6M	0/-8	0/-50
CF8M,CF10M,CF10-1M,CF12M	0/-9	0/-50
CF12-1M,CF16M,CF18M,CF20-1M	0/-11	0/-50
CF20M,CF24M,CF24-1M,CF30M	0/-13	0/-50
CF30-1M,CF30-2M	0/-15	0/-50

ACCESSORIES

TYPE	STOP PLUG	RESIN PLUG	NUT
CF5M	—	—	Attached
CF6M/CF8M/CF10M/CF10-1M	—	φ 4 Attached	Attached
CF10MK/CF10-1MK	φ 4 Attached	φ 4 Attached	Attached
CF12M/CF12-1M/CF16M/CF18M	φ 6 Attached	φ 6 Attached	Attached
CF20M/CF20-1M/CF24M/CF24-1M/CF30M/CF30-1M/CF30-2M	φ 8 Attached	φ 8 Attached	Attached

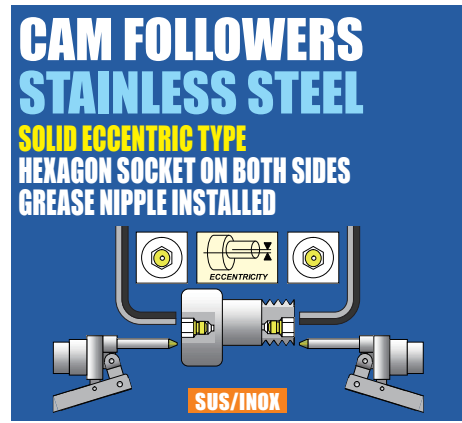

CFH..MAB



CFH..VMAB

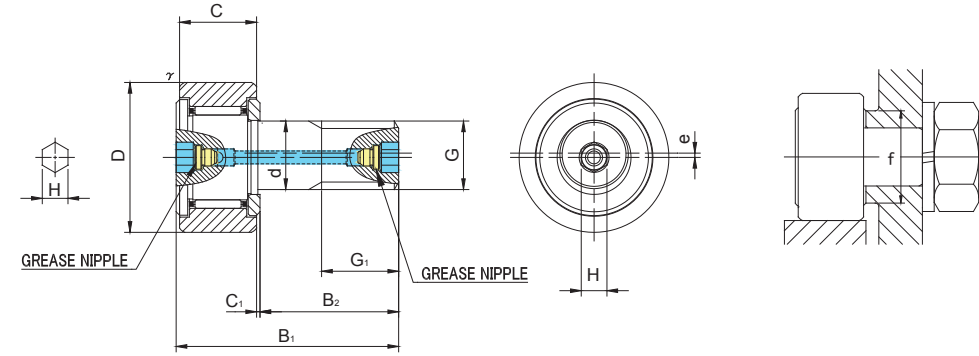

CFH..MAB TYPE

Prepacked Grease

Stud diameter (mm)	h7 tolerance	Designation				Dimensions (mm)												Basic dynamic load rating	Basic static load rating	Largest permissible load	Limiting speed *	Track load capacity		Max tightening torque	Mass
		Cylindrical outer ring		Crowned outer ring R500(CF12 ~ CF18) R1000(CF20 ≤)		D	C	d	G	G1	B1	B2	C1	H	r <sub>s</sub> min	e	f min					Cr N	Cor N		
12	0 -0.018	CFH12MAB	CFH12MUUAB	CFH12MRAB	CFH12MUURAB	30	14	12	M12×1.5	13	40	25	0.6	6	0.6	0.4	20	7 300	9 010	9 800	14 000	7 060	2 450	22	95
		CFH12VMAB	CFH12VMUAB	CFH12VMRAB	CFH12VMUURAB													12 350	18 120	11 270	6 000				
12	0 -0.018	CFH12-1MAB	CFH12-1MUAB	CFH12-1MRAB	CFH12-1MUURAB	32	14	12	M12×1.5	13	40	25	0.6	6	0.6	0.4	20	7 300	9 010	9 800	14 000	7 450	2 740	22	105
		CFH12-1VMAB	CFH12-1VMUAB	CFH12-1VMRAB	CFH12-1VMUURAB													12 350	18 120	11 270	6 000				
16	0 -0.018	CFH16MAB	CFH16MUUAB	CFH16MRAB	CFH16MUURAB	35	18	16	M16×1.5	17	52	32.5	0.8	6	0.6	0.5	24	11 080	16 860	18 330	10 000	11 200	3 140	58	170
		CFH16VMAB	CFH16VMUAB	CFH16VMRAB	CFH16VMUURAB													19 020	34 610	19 800	4 500				
18	0 -0.018	CFH18MAB	CFH18MUUAB	CFH18MRAB	CFH18MUURAB	40	20	18	M18×1.5	19	58	36.5	0.8	6	1	0.6	26	13 520	23 180	25 200	8 500	14 400	3 720	87	250
		CFH18VMAB	CFH18VMUAB	CFH18VMRAB	CFH18VMUURAB													23 250	47 240	26 560	3 500				
20	0 -0.021	CFH20MAB	CFH20MUUAB	CFH20MRAB	CFH20MUURAB	52	24	20	M20×1.5	21	66	40.5	0.8	8	1	0.7	36	19 020	31 830	32 140	7 000	23 200	8 230	120	460
		CFH20VMAB	CFH20VMUAB	CFH20VMRAB	CFH20VMUURAB													30 470	59 320	32 140	3 500				
20	0 -0.021	CFH20-1MAB	CFH20-1MUAB	CFH20-1MRAB	CFH20-1MUURAB	47	24	20	M20×1.5	21	66	40.5	0.8	8	1	0.7	36	19 020	31 830	32 140	7 000	21 000	7 150	120	385
		CFH20-1VMAB	CFH20-1VMUAB	CFH20-1VMRAB	CFH20-1VMUURAB													30 470	59 320	32 140	3 500				

CFH..MAB TYPE has oil holes (grease nipple) which are prepared in the stud head and thread side, also an oil hole is prepared outer surface of stud.

\* Without seals, suitable for grease lubrication. In case of oil lubrication, up to 130% of this value shall be permissible, and 70% of this value shall apply for types with seals.

OUTER RINGS TOLERANCE (µm)

TYPE	Cylindrical outer ring	Crowned outer ring
CF12	0/-9	0/-50
CF12-1,CF16,CF18,CF20-1	0/-11	0/-50
CF20,CF24,CF24-1,CF30	0/-13	0/-50
CF30-1,CF30-2	0/-15	0/-50

ACCESSORIES

TYPE	Grease Nipple	NUT
All types	Installed	Attached



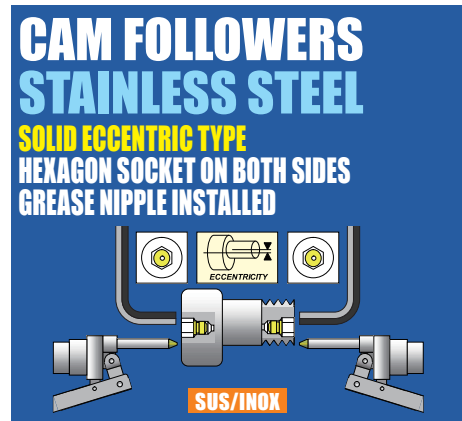

CFH..MAB



CFH..VMAB

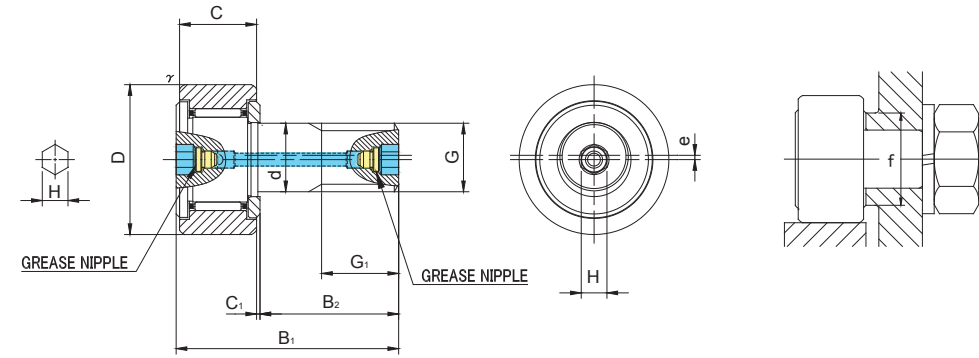

CFH..MAB TYPE

Prepacked Grease

Stud diameter (mm)	h7 tolerance	Designation				Dimensions (mm)												Basic dynamic load rating Cr N	Basic static load rating Cor N	Largest permissible load N	Limiting speed * rpm	Track load capacity		Max tightening torque N·m	Mass g (approx)
		Cylindrical outer ring		Crowned outer ring R1000(CF24 ≤)		D	C	d	G	G1	B1	B2	C1	H	rs min	e	f min					Cylindrical outer ring N	Crowned outer ring N		
		Without seals	With seals	Without seals	With seals																				
24	0 -0.021	CFH24MAB	CFH24MUUAB	CFH24MRAB	CFH24MUURAB	62	29	24	M24×1.5	25	80	49.5	0.8	8	1	0.8	40	28 040	48 410	49 500	6 500	34 200	10 500	220	815
		CFH24VMAB	CFH24VMUAB	CFH24VMRAB	CFH24VMUURAB													42 820	84 650	49 500	3 000				
24	0 -0.021	CFH24-1MAB	CFH24-1MUUAB	CFH24-1MRAB	CFH24-1MUURAB	72	29	24	M24×1.5	25	80	49.5	0.8	8	1	0.8	40	28 040	48 410	49 500	6 500	39 800	12 900	220	1 140
		CFH24-1VMAB	CFH24-1VMUAB	CFH24-1VMRAB	CFH24-1VMUURAB													42 820	84 650	49 500	3 000				
30	0 -0.021	CFH30MAB	CFH30MUUAB	CFH30MRAB	CFH30MUURAB	80	35	30	M30×1.5	32	100	63	1	8	1	1	46	41 740	78 250	73 700	5 000	52 600	14 900	450	1 870
		CFH30VMAB	CFH30VMUAB	CFH30VMRAB	CFH30VMUURAB													62 210	132 530	73 700	2 200				
30	0 -0.021	CFH30-1MAB	CFH30-1MUUAB	CFH30-1MRAB	CFH30-1MUURAB	85	35	30	M30×1.5	32	100	63	1	8	1	1	46	41 740	78 250	73 700	5 000	56 000	16 100	450	2 030
		CFH30-1VMAB	CFH30-1VMUAB	CFH30-1VMRAB	CFH30-1VMUURAB													62 210	132 530	73 700	2 200				
30	0 -0.021	CFH30-2MAB	CFH30-2MUUAB	CFH30-2MRAB	CFH30-2MUURAB	90	35	30	M30×1.5	32	100	63	1	8	1	1	46	41 740	78 250	73 700	5 000	59 300	17 300	450	2 220
		CFH30-2VMAB	CFH30-2VMUAB	CFH30-2VMRAB	CFH30-2VMUURAB													62 210	132 530	73 700	2 200				

CFH..MAB TYPE has oil holes (grease nipple) which are prepared in the stud head and thread side, also an oil hole is prepared outer surface of stud.

\* Without seals, suitable for grease lubrication. In case of oil lubrication, up to 130% of this value shall be permissible, and 70% of this value shall apply for types with seals.

OUTER RINGS TOLERANCE (µm)

TYPE	Cylindrical outer ring	Crowned outer ring
CF12	0/-9	0/-50
CF12-1,CF16,CF18,CF20-1	0/-11	0/-50
CF20,CF24,CF24-1,CF30	0/-13	0/-50
CF30-1,CF30-2	0/-15	0/-50

ACCESSORIES

TYPE	Grease Nipple	NUT
All types	Installed	Attached



**CAM FOLLOWERS**  
**STAINLESS STEEL**  
**SOLID ECCENTRIC TYPE**  
**HEXAGON SOCKET ON STUD HEAD**

SUS/INOX

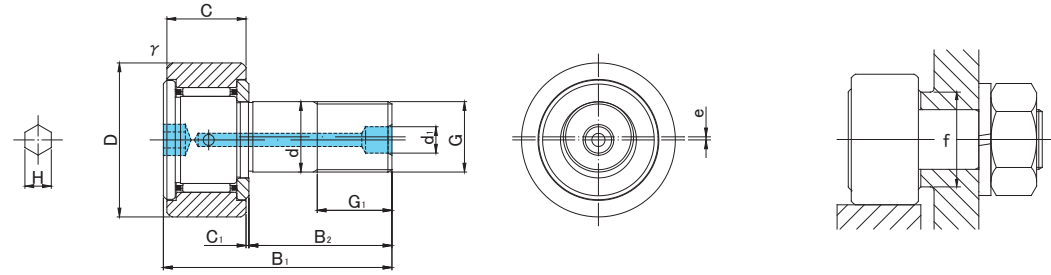
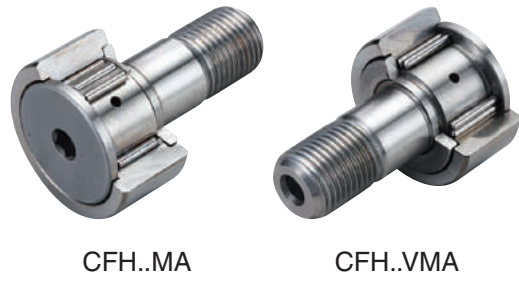

**CFH..MA TYPE**

Prepacked Grease

Stud diameter (mm)	h7 tolerance	Designation				Dimensions (mm)												Basic dynamic load rating	Basic static load rating	Largest permissible load	Limiting speed *	Track load capacity		Max tightening torque	Mass							
		Cylindrical outer ring		Crowned outer ring R500(CF16 ~ CF18) R1000(CF20 ≤)		D	C	d	G	G1	B1	B2	C1	d1	H	r <sub>s</sub> min	e					f min	C <sub>r</sub> N			C <sub>o</sub> r N	N	rpm	Cylindrical outer ring N	Crowned outer ring N	N-m	g (approx)
		Without seals	With seals	Without seals	With seals																											
16	0 -0.018	CFH16MA	CFH16MUUA	CFH16MRA	CFH16MUURA	35	18	16	M16×1.5	17	52	32.5	0.8	6	6	0.6	0.5	24	11 080	16 860	18 330	10 000	11 200	3 140	58	170						
		CFH16VMA	CFH16VMUUA	CFH16VMRA	CFH16VMUURA																											
18	0 -0.018	CFH18MA	CFH18MUUA	CFH18MRA	CFH18MUURA	40	20	18	M18×1.5	19	58	36.5	0.8	6	6	1	0.6	26	13 520	23 180	25 200	8 500	14 400	3 720	87	250						
		CFH18VMA	CFH18VMUUA	CFH18VMRA	CFH18VMUURA																											
20	0 -0.021	CFH20MA	CFH20MUUA	CFH20MRA	CFH20MUURA	52	24	20	M20×1.5	21	66	40.5	0.8	8	8	1	0.7	36	19 020	31 830	32 140	7 000	23 200	8 230	120	460						
		CFH20VMA	CFH20VMUUA	CFH20VMRA	CFH20VMUURA																											
20	0 -0.021	CFH20-1MA	CFH20-1MUUA	CFH20-1MRA	CFH20-1MUURA	47	24	20	M20×1.5	21	66	40.5	0.8	8	8	1	0.7	36	19 020	31 830	32 140	7 000	21 000	7 150	120	385						
		CFH20-1VMA	CFH20-1VMUUA	CFH20-1VMRA	CFH20-1VMUURA																											
24	0 -0.021	CFH24MA	CFH24MUUA	CFH24MRA	CFH24MUURA	62	29	24	M24×1.5	25	80	49.5	0.8	8	8	1	0.8	40	28 040	48 410	49 500	6 500	34 200	10 500	220	815						
		CFH24VMA	CFH24VMUUA	CFH24VMRA	CFH24VMUURA																											
24	0 -0.021	CFH24-1MA	CFH24-1MUUA	CFH24-1MRA	CFH24-1MUURA	72	29	24	M24×1.5	25	80	49.5	0.8	8	8	1	0.8	40	28 040	48 410	49 500	6 500	39 800	12 900	220	1 140						
		CFH24-1VMA	CFH24-1VMUUA	CFH24-1VMRA	CFH24-1VMUURA																											
30	0 -0.021	CFH30MA	CFH30MUUA	CFH30MRA	CFH30MUURA	80	35	30	M30×1.5	32	100	63	1	8	8	1	1	46	41 740	78 250	73 700	5 000	52 600	14 900	450	1 870						
		CFH30VMA	CFH30VMUUA	CFH30VMRA	CFH30VMUURA																											
30	0 -0.021	CFH30-1MA	CFH30-1MUUA	CFH30-1MRA	CFH30-1MUURA	85	35	30	M30×1.5	32	100	63	1	8	8	1	1	46	41 740	78 250	73 700	5 000	56 000	16 100	450	2 030						
		CFH30-1VMA	CFH30-1VMUUA	CFH30-1VMRA	CFH30-1VMUURA																											
30	0 -0.021	CFH30-2MA	CFH30-2MUUA	CFH30-2MRA	CFH30-2MUURA	90	35	30	M30×1.5	32	100	63	1	8	8	1	1	46	41 740	78 250	73 700	5 000	59 300	17 300	450	2 220						
		CFH30-2VMA	CFH30-2VMUUA	CFH30-2VMRA	CFH30-2VMUURA																											

\* Without seals, suitable for grease lubrication. In case of oil lubrication, up to 130% of this value shall be permissible, and 70% of this value shall apply for types with seals.

OUTER RINGS TOLERANCE (μm)

TYPE	Cylindrical outer ring	Crowned outer ring
CF5M,CF6M	0/-8	0/-50
CF8M,CF10M,CF10-1M,CF12M	0/-9	0/-50
CF12-1M,CF16M,CF18M,CF20-1M	0/-11	0/-50
CF20M,CF24M,CF24-1M,CF30M	0/-13	0/-50
CF30-1M,CF30-2M	0/-15	0/-50

ACCESSORIES

TYPE	STOP PLUG	RESIN PLUG	NUT
CF3M/CF4M/CF5M	—	—	Attached
CF6M/CF8M/CF10M/CF10-1M	—	—	Attached
CF12M/CF12-1M/CF16M/CF18M	φ 6 Attached	φ 6 Attached	Attached
CF20M/CF20-1M/CF24M/CF24-1M/CF30M/CF30-1M/CF30-2M	φ 8 Attached	φ 8 Attached	Attached

**CAM FOLLOWERS**  
**STAINLESS STEEL**  
**SOLID ECCENTRIC TYPE**  
**SCREWDRIVER SLOT HEAD**

ECCENTRICITY

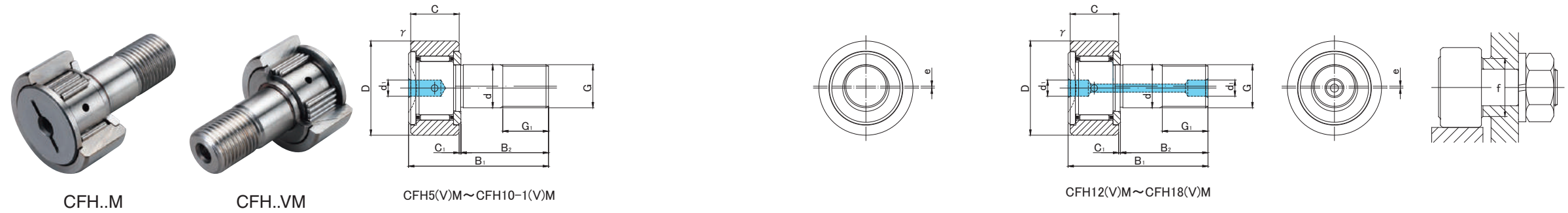

**CFH..M TYPE**

Prepacked Grease

Stud diameter (mm)	Designation				Dimensions (mm)													Basic dynamic load rating	Basic static load rating	Largest permissible load	Limiting speed *	Track load capacity		Max tightening torque	Mass					
	Cylindrical outer ring		Crowned outer ring R250(CF5) R500(CF6 ~ CF18)		D	C	d	G	G1	B1	B2	C1	d1	r <sub>s</sub> min	e	f min	Cr N					Cor N	N			rpm	Cylindrical outer ring N	Crowned outer ring N	N·m	g (approx)
	Without seals	With seals	Without seals	With seals																										
5	CFH 5M	CFH 5MUU	CFH 5MR	CFH 5MUUR	13	9	5	M5×0.8	7.5	23	13	0.5	3.1	0.3	0.2	9.7	2 880	2 540	1 420	29 000	2 250	530	2	10.5						
	CFH 5VM	CFH 5VMUU	CFH 5VMR	CFH 5VMUUR																										
6	CFH 6M	CFH 6MUU	CFH 6MR	CFH 6MUUR	16	11	6	M6×1	8	28	16	0.6	4	0.3	0.25	11	3 330	3 330	2 110	25 000	3 430	1 080	3	18.5						
	CFH 6VM	CFH 6VMUU	CFH 6VMR	CFH 6VMUUR																										
8	CFH 8M	CFH 8MUU	CFH 8MR	CFH 8MUUR	19	11	8	M8×1.25	10	32	20	0.6	4	0.3	0.25	13	3 960	4 330	4 710	20 000	4 020	1 370	8	28.5						
	CFH 8VM	CFH 8VMUU	CFH 8VMR	CFH 8VMUUR																										
10	CFH10M	CFH10MUU	CFH10MR	CFH10MUUR	22	12	10	M10×1.25	12	36	23	0.6	4	0.3	0.3	15	4 950	6 310	6 860	17 000	4 700	1 670	15	45						
	CFH10VM	CFH10VMUU	CFH10VMR	CFH10VMUUR																										
10	CFH10-1M	CFH10-1MUU	CFH10-1MR	CFH10-1MUUR	26	12	10	M10×1.25	12	36	23	0.6	4	0.3	0.3	15	4 950	6 310	6 860	17 000	5 490	2 060	15	60						
	CFH10-1VM	CFH10-1VMUU	CFH10-1VMR	CFH10-1VMUUR																										
12	CFH12M	CFH12MUU	CFH12MR	CFH12MUUR	30	14	12	M12×1.5	13	40	25	0.6	6	0.6	0.4	20	7 300	9 010	9 800	14 000	7 060	2 450	22	95						
	CFH12VM	CFH12VMUU	CFH12VMR	CFH12VMUUR																										
12	CFH12-1M	CFH12-1MUU	CFH12-1MR	CFH12-1MUUR	32	14	12	M12×1.5	13	40	25	0.6	6	0.6	0.4	20	7 300	9 010	9 800	14 000	7 450	2 740	22	105						
	CFH12-1VM	CFH12-1VMUU	CFH12-1VMR	CFH12-1VMUUR																										
16	CFH16M	CFH16MUU	CFH16MR	CFH16MUUR	35	18	16	M16×1.5	17	52	32.5	0.8	6	0.6	0.5	24	11 080	16 860	18 330	10 000	11 200	3 140	58	170						
	CFH16VM	CFH16VMUU	CFH16VMR	CFH16VMUUR																										
18	CFH18M	CFH18MUU	CFH18MR	CFH18MUUR	40	20	18	M18×1.5	19	58	36.5	0.8	6	1	0.6	26	13 520	23 180	25 200	8 500	14 400	3 720	87	250						
	CFH18VM	CFH18VMUU	CFH18VMR	CFH18VMUUR																										

\* Without seals, suitable for grease lubrication. In case of oil lubrication, up to 130% of this value shall be permissible, and 70% of this value shall apply for types with seals.

**OUTER RINGS TOLERANCE (μm)**

TYPE	Cylindrical outer ring	Crowned outer ring
CF5M,CF6M	0/-8	0/-50
CF8M,CF10M,CF10-1M,CF12M	0/-9	0/-50
CF12-1M,CF16M,CF18M,CF20-1M	0/-11	0/-50
CF20M,CF24M,CF24-1M,CF30M	0/-13	0/-50
CF30-1M,CF30-2M	0/-15	0/-50

**ACCESSORIES**

TYPE	STOP PLUG	RESIN PLUG	NUT
CF5M	—	—	Attached
CF6M/CF8M/CF10M/CF10-1M	—	φ 4 Attached	Attached
CF12M/CF12-1M/CF16M/CF18M	φ 6 Attached	φ 6 Attached	Attached
CF20M/CF20-1M/CF24M/CF24-1M/CF30M/CF30-1M/CF30-2M	φ 8 Attached	φ 8 Attached	Attached



**CAM FOLLOWERS**  
**STAINLESS STEEL**  
**SOLID ECCENTRIC TYPE**  
**SCREWDRIVER SLOT HEAD**

ECCENTRICITY



CFH..M



CFH..VM

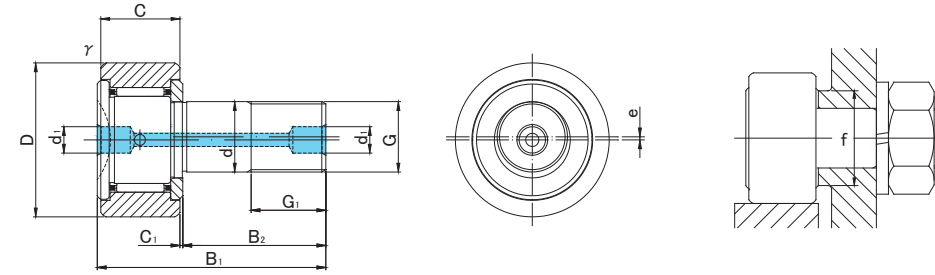

**CFH..M TYPE**

Prepacked Grease

Stud diameter (mm)	h7 tolerance	Designation				Dimensions (mm)												Basic dynamic load rating Cr N	Basic static load rating Cor N	Largest permissible load N	Limiting speed * rpm	Track load capacity		Max tightening torque N·m	Mass g (approx)
		Cylindrical outer ring		Crowned outer ring R1000(CF20 ≤)		D	C	d	G	G1	B1	B2	C1	d1	rs min	e	f min					Cylindrical outer ring N	Crowned outer ring N		
		Without seals	With seals	Without seals	With seals																				
20	0 -0.021	CFH20M	CFH20MUU	CFH20MR	CFH20MUUR	52	24	20	M20×1.5	21	66	40.5	0.8	8	1	0.7	36	19 020	31 830	32 140	7 000	23 200	8 230	120	460
		CFH20VM	CFH20VMUU	CFH20VMR	CFH20VMUUR													30 470	59 320	32 140	3 500				
20	0 -0.021	CFH20-1M	CFH20-1MUU	CFH20-1MR	CFH20-1MUUR	47	24	20	M20×1.5	21	66	40.5	0.8	8	1	0.7	36	19 020	31 830	32 140	7 000	21 000	7 150	120	385
		CFH20-1VM	CFH20-1VMUU	CFH20-1VMR	CFH20-1VMUUR													30 470	59 320	32 140	3 500				
24	0 -0.021	CFH24M	CFH24MUU	CFH24MR	CFH24MUUR	62	29	24	M24×1.5	25	80	49.5	0.8	8	1	0.8	40	28 040	48 410	49 500	6 500	34 200	10 500	220	815
		CFH24VM	CFH24VMUU	CFH24VMR	CFH24VMUUR													42 820	84 650	49 500	3 000				
24	0 -0.021	CFH24-1M	CFH24-1MUU	CFH24-1MR	CFH24-1MUUR	72	29	24	M24×1.5	25	80	49.5	0.8	8	1	0.8	40	28 040	48 410	49 500	6 500	39 800	12 900	220	1 140
		CFH24-1VM	CFH24-1VMUU	CFH24-1VMR	CFH24-1VMUUR													42 820	84 650	49 500	3 000				
30	0 -0.021	CFH30M	CFH30MUU	CFH30MR	CFH30MUUR	80	35	30	M30×1.5	32	100	63	1	8	1	1	46	41 740	78 250	73 700	5 000	52 600	14 900	450	1 870
		CFH30VM	CFH30VMUU	CFH30VMR	CFH30VMUUR													62 210	132 530	73 700	2 200				
30	0 -0.021	CFH30-1M	CFH30-1MUU	CFH30-1MR	CFH30-1MUUR	85	35	30	M30×1.5	32	100	63	1	8	1	1	46	41 740	78 250	73 700	5 000	56 000	16 100	450	2 030
		CFH30-1VM	CFH30-1VMUU	CFH30-1VMR	CFH30-1VMUUR													62 210	132 530	73 700	2 200				
30	0 -0.021	CFH30-2M	CFH30-2MUU	CFH30-2MR	CFH30-2MUUR	90	35	30	M30×1.5	32	100	63	1	8	1	1	46	41 740	78 250	73 700	5 000	59 300	17 300	450	2 220
		CFH30-2VM	CFH30-2VMUU	CFH30-2VMR	CFH30-2VMUUR													62 210	132 530	73 700	2 200				

\* Without seals, suitable for grease lubrication. In case of oil lubrication, up to 130% of this value shall be permissible, and 70% of this value shall apply for types with seals.

OUTER RINGS TOLERANCE (µm)

TYPE	Cylindrical outer ring	Crowned outer ring
CF5M,CF6M	0/-8	0/-50
CF8M,CF10M,CF10-1M,CF12M	0/-9	0/-50
CF12-1M,CF16M,CF18M,CF20-1M	0/-11	0/-50
CF20M,CF24M,CF24-1M,CF30M	0/-13	0/-50
CF30-1M,CF30-2M	0/-15	0/-50

ACCESSORIES

TYPE	STOP PLUG	RESIN PLUG	NUT
CF5M	—	—	Attached
CF6M/CF8M/CF10M/CF10-1M	—	φ 4 Attached	Attached
CF12M/CF12-1M/CF16M/CF18M	φ 6 Attached	φ 6 Attached	Attached
CF20M/CF20-1M/CF24M/CF24-1M/CF30M/CF30-1M/CF30-2M	φ 8 Attached	φ 8 Attached	Attached

CFH..M

CFH..M

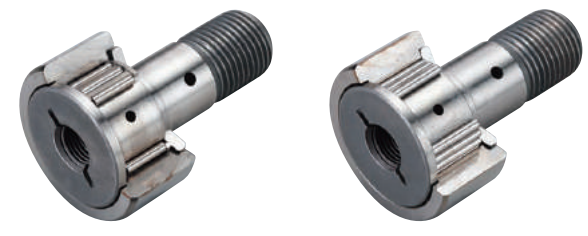
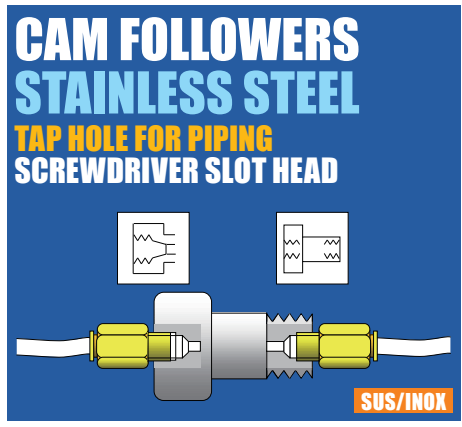

CFT..M

CFT..VM

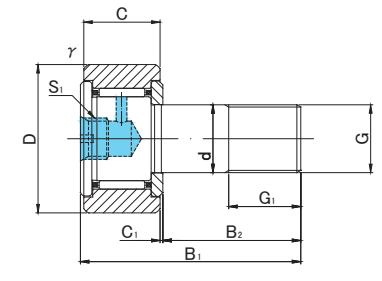

CFT6(V)M~CFT10-1(V)M

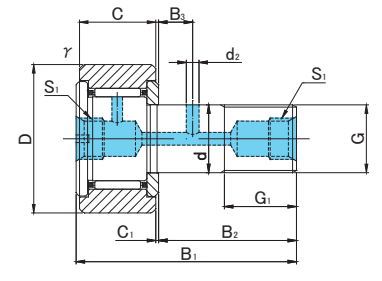

CFT12(V)M~CFT18(V)M

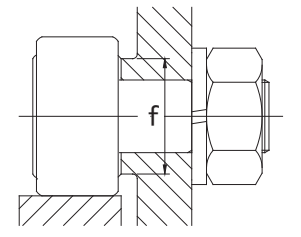

CFT..M TYPE

Prepacked Grease

Stud diameter (mm)	h7 tolerance	Designation				Dimensions (mm)													Basic dynamic load rating Cr N	Basic static load rating Cor N	Largest permissible load N	Limiting speed * rpm	Track load capacity		Max tightening torque N-m	Mass g (approx)
		Cylindrical outer ring		Crowned outer ring R500(CF6 ~ CF18)		D	C	d	G	G1	B1	B2	B3	C1	S1	d2	rs min	f min					Cylindrical outer ring N	Crowned outer ring N		
6	0 -0.012	CFT 6M	CFT 6MUU	CFT 6MR	CFT 6MUUR	16	11	6	M6×1	8	28	16	—	0.6	M6×0.75	—	0.3	11	3 330	3 330	2 110	25 000	3 430	1 080	3	18.5
		CFT 6VM	CFT 6VMUU	CFT 6VMR	CFT 6VMUUR														6 400	7 840	2 110	12 000				
8	0 -0.015	CFT 8M	CFT 8MUU	CFT 8MR	CFT 8MUUR	19	11	8	M8×1.25	10	32	20	—	0.6	M6×0.75	—	0.3	13	3 960	4 330	4 710	20 000	4 020	1 370	8	28.5
		CFT 8VM	CFT 8VMUU	CFT 8VMR	CFT 8VMUUR														7 470	10 270	4 710	9 000				
10	0 -0.015	CFT10M	CFT10MUU	CFT10MR	CFT10MUUR	22	12	10	M10×1.25	12	36	23	—	0.6	M6×0.75	—	0.3	15	4 950	6 310	6 860	17 000	4 700	1 670	15	45
		CFT10VM	CFT10VMUU	CFT10VMR	CFT10VMUUR														8 740	13 340	7 450	7 500				
10	0 -0.015	CFT10-1M	CFT10-1MUU	CFT10-1MR	CFT10-1MUUR	26	12	10	M10×1.25	12	36	23	—	0.6	M6×0.75	—	0.3	15	4 950	6 310	6 860	17 000	5 490	2 060	15	60
		CFT10-1VM	CFT10-1VMUU	CFT10-1VMR	CFT10-1VMUUR														8 740	13 340	7 450	7 500				
12	0 -0.018	CFT12M	CFT12MUU	CFT12MR	CFT12MUUR	30	14	12	M12×1.5	13	40	25	6	0.6	M6×0.75	3	0.6	20	7 300	9 010	7 840	14 000	7 060	2 450	22	95
		CFT12VM	CFT12VMUU	CFT12VMR	CFT12VMUUR														12 350	18 120	9 010	6 000				
12	0 -0.018	CFT12-1M	CFT12-1MUU	CFT12-1MR	CFT12-1MUUR	32	14	12	M12×1.5	13	40	25	6	0.6	M6×0.75	3	0.6	20	7 300	9 010	7 840	14 000	7 450	2 740	22	105
		CFT12-1VM	CFT12-1VMUU	CFT12-1VMR	CFT12-1VMUUR														12 350	18 120	9 010	6 000				
16	0 -0.018	CFT16M	CFT16MUU	CFT16MR	CFT16MUUR	35	18	16	M16×1.5	17	52	32.5	8	0.8	Rc1/8	3	0.6	24	11 080	16 860	14 660	10 000	11 200	3 140	58	170
		CFT16VM	CFT16VMUU	CFT16VMR	CFT16VMUUR														19 020	34 610	15 840	4 500				
18	0 -0.018	CFT18M	CFT18MUU	CFT18MR	CFT18MUUR	40	20	18	M18×1.5	19	58	36.5	8	0.8	Rc1/8	3	1	26	13 520	23 180	20 160	8 500	14 400	3 720	87	250
		CFT18VM	CFT18VMUU	CFT18VMR	CFT18VMUUR														23 250	47 240	21 240	3 500				

\* Without seals, suitable for grease lubrication. In case of oil lubrication, up to 130% of this value shall be permissible, and 70% of this value shall apply for types with seals.

OUTER RINGS TOLERANCE (μm)

TYPE	Cylindrical outer ring	Crowned outer ring
CF6M	0/-8	0/-50
CF8M,CF10M,CF10-1M,CF12M	0/-9	0/-50
CF12-1M,CF16M,CF18M,CF20-1M	0/-11	0/-50
CF20M,CF24M,CF24-1M,CF30M	0/-13	0/-50
CF30-1M,CF30-2M	0/-15	0/-50

ACCESSORIES

TYPE	Image
All types	NUT Attached

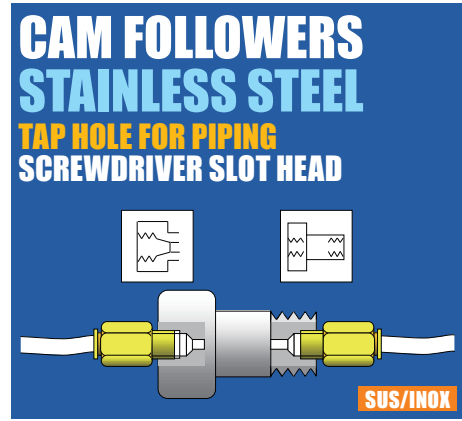

CFT..M



CFT..VM

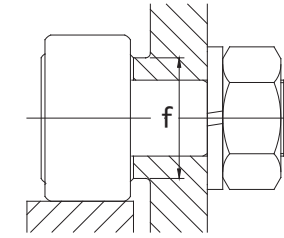
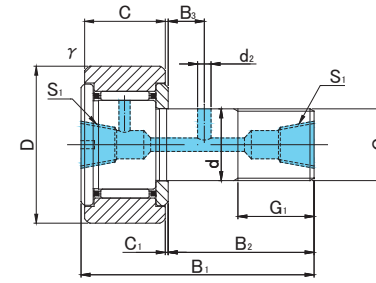

CFT..M TYPE

Prepacked Grease

Stud diameter (mm)	h7 tolerance	Designation				Dimensions (mm)													Basic dynamic load rating	Basic static load rating	Largest permissible load	Limiting speed *	Track load capacity		Max tightening torque	Mass
		Cylindrical outer ring		Crowned outer ring R1000(CF20 ≤)		D	C	d	G	G1	B1	B2	B3	C1	S1	d2	rs min	f min					Cr N	Cor N		
20	0 -0.021	CFT20M	CFT20MUU	CFT20MR	CFT20MUUR	52	24	20	M20×1.5	21	66	40.5	9	0.8	Rc1/8	4	1	36	19 020	31 830	25 710	7 000	23 200	8 230	120	460
		CFT20VM	CFT20VMUU	CFT20VMR	CFT20VMUUR														30 470	59 320	25 710	3 500				
20	0 -0.021	CFT20-1M	CFT20-1MUU	CFT20-1MR	CFT20-1MUUR	47	24	20	M20×1.5	21	66	40.5	9	0.8	Rc1/8	4	1	36	19 020	31 830	25 710	7 000	21 000	7 150	120	385
		CFT20-1VM	CFT20-1VMUU	CFT20-1VMR	CFT20-1VMUUR														30 470	59 320	25 710	3 500				
24	0 -0.021	CFT24M	CFT24MUU	CFT24MR	CFT24MUUR	62	29	24	M24×1.5	25	80	49.5	11	0.8	Rc1/8	4	1	40	28 040	48 410	39 600	6 500	34 200	10 500	220	815
		CFT24VM	CFT24VMUU	CFT24VMR	CFT24VMUUR														42 820	84 650	39 600	3 000				
24	0 -0.021	CFT24-1M	CFT24-1MUU	CFT24-1MR	CFT24-1MUUR	72	29	24	M24×1.5	25	80	49.5	11	0.8	Rc1/8	4	1	40	28 040	48 410	39 600	6 500	39 800	12 900	220	1 140
		CFT24-1VM	CFT24-1VMUU	CFT24-1VMR	CFT24-1VMUUR														42 820	84 650	39 600	3 000				
30	0 -0.021	CFT30M	CFT30MUU	CFT30MR	CFT30MUUR	80	35	30	M30×1.5	32	100	63	15	1	Rc1/8	4	1	46	41 740	78 250	58 960	5 000	52 600	14 900	450	1 870
		CFT30VM	CFT30VMUU	CFT30VMR	CFT30VMUUR														62 210	132 530	58 960	2 200				
30	0 -0.021	CFT30-1M	CFT30-1MUU	CFT30-1MR	CFT30-1MUUR	85	35	30	M30×1.5	32	100	63	15	1	Rc1/8	4	1	46	41 740	78 250	58 960	5 000	56 000	16 100	450	2 030
		CFT30-1VM	CFT30-1VMUU	CFT30-1VMR	CFT30-1VMUUR														62 210	132 530	58 960	2 200				
30	0 -0.021	CFT30-2M	CFT30-2MUU	CFT30-2MR	CFT30-2MUUR	90	35	30	M30×1.5	32	100	63	15	1	Rc1/8	4	1	46	41 740	78 250	58 960	5 000	59 300	17 300	450	2 220
		CFT30-2VM	CFT30-2VMUU	CFT30-2VMR	CFT30-2VMUUR														62 210	132 530	58 960	2 200				

\* Without seals, suitable for grease lubrication. In case of oil lubrication, up to 130% of this value shall be permissible, and 70% of this value shall apply for types with seals.

OUTER RINGS TOLERANCE (µm)

TYPE	Cylindrical outer ring	Crowned outer ring
CF6M	0/-8	0/-50
CF8M,CF10M,CF10-1M,CF12M	0/-9	0/-50
CF12-1M,CF16M,CF18M,CF20-1M	0/-11	0/-50
CF20M,CF24M,CF24-1M,CF30M	0/-13	0/-50
CF30-1M,CF30-2M	0/-15	0/-50

ACCESSORIES

TYPE	
All types	NUT Attached



CFT..MA



CFT..VMA

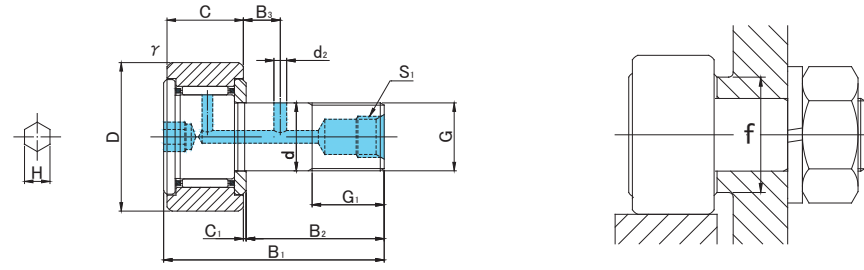

CFT..MA TYPE

Prepacked Grease

Stud diameter (mm)	h7 tolerance	Designation				Dimensions (mm)																Basic dynamic load rating	Basic static load rating	Largest permissible load	Limiting speed *	Track load capacity		Max tightening torque	Mass
		Cylindrical outer ring		Crowned outer ring R500(CF12 ~ CF18) R1000(CF20 ≤)		D	C	d	G	G1	B1	B2	B3	C1	S1	d2	H	rs min	f min	Cr N	Cor N					N	rpm		
12	0 -0.018	CFT12MA	CFT12MUUA	CFT12MRA	CFT12MUURA	30	14	12	M12×1.5	13	40	25	6	0.6	M6×0.75	3	6	0.6	20	7 300	9 010	7 840	14 000	7 060	2 450	22	95		
		CFT12VMA	CFT12VMUUA	CFT12VMRA	CFT12VMUURA															12 350	18 120	9 010	6 000						
12	0 -0.018	CFT12-1MA	CFT12-1MUUA	CFT12-1MRA	CFT12-1MUURA	32	14	12	M12×1.5	13	40	25	6	0.6	M6×0.75	3	6	0.6	20	7 300	9 010	7 840	14 000	7 450	2 740	22	105		
		CFT12-1VMA	CFT12-1VMUUA	CFT12-1VMRA	CFT12-1VMUURA															12 350	18 120	9 010	6 000						
16	0 -0.018	CFT16MA	CFT16MUUA	CFT16MRA	CFT16MUURA	35	18	16	M16×1.5	17	52	32.5	8	0.8	Rc1/8	3	6	0.6	24	11 080	16 860	14 660	10 000	11 200	3 140	58	170		
		CFT16VMA	CFT16VMUUA	CFT16VMRA	CFT16VMUURA															19 020	34 610	15 840	4 500						
18	0 -0.018	CFT18MA	CFT18MUUA	CFT18MRA	CFT18MUURA	40	20	18	M18×1.5	19	58	36.5	8	0.8	Rc1/8	3	6	1	26	13 520	23 180	20 160	8 500	14 400	3 720	87	250		
		CFT18VMA	CFT18VMUUA	CFT18VMRA	CFT18VMUURA															23 250	47 240	21 240	3 500						
20	0 -0.021	CFT20MA	CFT20MUUA	CFT20MRA	CFT20MUURA	52	24	20	M20×1.5	21	66	40.5	9	0.8	Rc1/8	4	8	1	36	19 020	31 830	25 710	7 000	23 200	8 230	120	460		
		CFT20VMA	CFT20VMUUA	CFT20VMRA	CFT20VMUURA															30 470	59 320	25 710	3 500						
20	0 -0.021	CFT20-1MA	CFT20-1MUUA	CFT20-1MRA	CFT20-1MUURA	47	24	20	M20×1.5	21	66	40.5	9	0.8	Rc1/8	4	8	1	36	19 020	31 830	25 710	7 000	21 000	7 150	120	385		
		CFT20-1VMA	CFT20-1VMUUA	CFT20-1VMRA	CFT20-1VMUURA															30 470	59 320	25 710	3 500						
24	0 -0.021	CFT24MA	CFT24MUUA	CFT24MRA	CFT24MUURA	62	29	24	M24×1.5	25	80	49.5	11	0.8	Rc1/8	4	8	1	40	28 040	48 410	39 600	6 500	34 200	10 500	220	815		
		CFT24VMA	CFT24VMUUA	CFT24VMRA	CFT24VMUURA															42 820	84 650	39 600	3 000						
24	0 -0.021	CFT24-1MA	CFT24-1MUUA	CFT24-1MRA	CFT24-1MUURA	72	29	24	M24×1.5	25	80	49.5	11	0.8	Rc1/8	4	8	1	40	28 040	48 410	39 600	6 500	39 800	12 900	220	1 140		
		CFT24-1VMA	CFT24-1VMUUA	CFT24-1VMRA	CFT24-1VMUURA															42 820	84 650	39 600	3 000						
30	0 -0.021	CFT30MA	CFT30MUUA	CFT30MRA	CFT30MUURA	80	35	30	M30×1.5	32	100	63	15	1	Rc1/8	4	8	1	46	41 740	78 250	58 960	5 000	52 600	14 900	450	1 870		
		CFT30VMA	CFT30VMUUA	CFT30VMRA	CFT30VMUURA															62 210	132 530	58 960	2 200						
30	0 -0.021	CFT30-1MA	CFT30-1MUUA	CFT30-1MRA	CFT30-1MUURA	85	35	30	M30×1.5	32	100	63	15	1	Rc1/8	4	8	1	46	41 740	78 250	58 960	5 000	56 000	16 100	450	2 030		
		CFT30-1VMA	CFT30-1VMUUA	CFT30-1VMRA	CFT30-1VMUURA															62 210	132 530	58 960	2 200						
30	0 -0.021	CFT30-2MA	CFT30-2MUUA	CFT30-2MRA	CFT30-2MUURA	90	35	30	M30×1.5	32	100	63	15	1	Rc1/8	4	8	1	46	41 740	78 250	58 960	5 000	59 300	17 300	450	2 220		
		CFT30-2VMA	CFT30-2VMUUA	CFT30-2VMRA	CFT30-2VMUURA															62 210	132 530	58 960	2 200						

\* Without seals, suitable for grease lubrication. In case of oil lubrication, up to 130% of this value shall be permissible, and 70% of this value shall apply for types with seals.

OUTER RINGS TOLERANCE (µm)

TYPE	Cylindrical outer ring	Crowned outer ring
CF12M	0/-9	0/-50
CF12-1M,CF16M,CF18M,CF20-1M	0/-11	0/-50
CF20M,CF24M,CF24-1M,CF30M	0/-13	0/-50
CF30-1M,CF30-2M	0/-15	0/-50

ACCESSORIES

TYPE	Image
All types	NUT Attached